

USER'S MANUAL

Thank you very much for purchasing the HITACHI Plasma Display. Before using your monitor, please carefully read the "SAFETY INSTRUCTIONS" and this "USER'S MANUAL" so you will know how to operate the monitor properly. Keep this manual in a safe place. You will find it useful in the future.

Notes on Installation Work:

This product is marketed assuming that it is installed by qualified personnel with enough skill and competence. Always have an installation specialist or your dealer install and set up the product. HITACHI cannot assume liabilities for damage caused by mistake in installation or mounting, misuse, modification or a natural disaster.

Note for Dealers:

After installation, be sure to deliver this manual to the customer and explain to the customer how to handle the product.

Important

Please read this User's Manual thoroughly, especially the Safety Instructions on Page 4 to 7. Mis-use may cause damage to your plasma monitor, which could shorten its lifespan, or cause injury to yourself. Should you encounter any difficulty in the set-up or operation of your monitor, firstly refer to the Troubleshooting guide at the rear of this manual.

In the unlikely event of a problem occurring with your plasma monitor, switch off at the mains sockets, pull out the plugs, and contact your dealer immediately.

CAUTION

Under no circumstances remove the rear cover of your plasma monitor.

Never guess or take any chances with electrical equipment of any kind - it is better to be safe than sorry!

Software Notice

It is prohibited for the end user of this product to copy, reverse engineer or reverse compile the software included therein, save to the extent permitted by law.

Plasma Monitor

After the plasma monitor has been on for any length of time, you will notice that the screen becomes warm. Please note that this is normal.

Sometimes the screen might have some tiny bright or dark spots. Please note that this is normal.

CAUTION

To prevent scratches or damages to the plasma screen, do not knock or rub the surface with sharp or hard objects. Clean the screen with a soft cloth moistened with warm water and dry with a soft cloth. A mild soap may be used if the screen is extremely dirty. Do not use harsh or abrasive cleaners!

CAUTION

Use a soft cloth to clean the cabinet and control panel of the monitor. When excessively soiled dilute a neutral detergent in water, wet and wring out the soft cloth and afterward wipe with a dry soft cloth.

Never use acid/alkaline detergent, alcoholic detergent, abrasive cleaner, powder soap, OA cleaner, car wax, glass cleaner, etc. especially because they would cause discoloration, scratches or cracks.

FEATURES

Large-screen, high-definition plasma display panel

The 42-inch color plasma display panel, with a resolution of 1024 (H) x 1024(V) pixels, the 37-inch color plasma display panel with a resolution of 1024(H) x 1024(V) pixels, and the 32-inch color plasma display panel with a resolution of 852(H) X 1024(V) pixels, creates a high-definition, large-screen (aspect ratio : 16:9) and low-profile flat display. Free from electromagnetic interferences from geomagnetic sources and ambient power lines, the panel produces high-quality display images free from color misconvergence and display distortion.

High Performance Digital Processor

A wide range of input signals can be handed, including composite, component, and HDMI.

High Definition Digital Processor creates the fine-textured image with dynamic contrast.

In addition, it corresponds to a broad array of personal computer signals, from 640 x 400 and 640 x 480 VGA to 1600 x 1200 UXGA. (Analog Input)

Easy-to-use remote control and on screen display system

The remote control included eases the work of setting display controls. Further, the on-screen display system, displays the status of signal reception and display control settings in an easy-to-view fashion.

Power saving system

The International ENERGY STAR® power saver feature saves power consumption automatically when input signals are not available.

When connected to a VESA DPMS-compliant PC, the monitor cuts its power consumption while it is idle.

Connecting to an Audio Visual Device

- Two composite/S terminals¹, three composite terminals², two component terminals², a HDMI terminal and a photo input terminal (37/42 only) have been added. A composite video output terminal is also provided as a monitoring output.
 - ¹ A composite/S terminal = A side input
 - ² Two composite terminal and two component terminal are used at the same time. The component terminal would govern.
- A wide range of devices other than personal computers can also be connected.
- A RGB input is possible to switch to component signals from the Menu screen.

Power Swivel Feature (TV model only)

It allows to turn the plasma display left or right within ± 30 degree using the remote control.

Options (AV monitor model only)

Plasma monitor speaker

CONTENTS

FEATURES	2
SAFETY INSTRUCTIONS	4
IMAGE RETENTION OF PLASMA DISPLAY ..	8
COMPONENT NAMES	9
Main Unit	9
Remote control	10
Loading Batteries	10
Handling the Remote Control	10
INSTALLATION INSTRUCTIONS	13
Installation	13
Anti-tumble measures	13
Connecting to an Audio Visual Device	14
Connecting to a PC	16
Mounting the Speaker Unit	17
Mounting the Side Input	19
Power Cord Connection	20
OPERATING INSTRUCTIONS	21
Turning Power On and Off	21
Input Switching	22
Size Switching	22
Volume Adjustment	24
Audio Mute	24
Power Swivel	25
Input Signal Screen Display	26
Displaying MULTI PICTURE	27
Picture Freezing	29
Photo Input Display (37/42 only)	30
Using the Menu Screen (On-screen display system)	33
SETUP MENU (TV mode)	34
SETUP MENU (Video mode)	36
SETUP MENU (RGB mode: RGB1 (DVI-PC), RGB2 (RGB))	37
FUNCTION MENU	39
PICTURE MENU (TV/Video mode)	40
PICTURE MENU (RGB mode)	43
AUDIO MENU	44
TIMER MENU	45
LANGUAGE MENU	45
OTHER FUNCTIONS	46
Automatic Store	46
Audio Switching	47
Power Save Mode	48
DVD Player/STB Selection	48
Signal Check (RGB mode)	49
TROUBLESHOOTING	50
Symptoms That Seemingly Appear to be Failures	50
Actions to Correct Abnormal Displays	52
PRODUCT SPECIFICATIONS	53
Signal Input	54
Recommended Signal List	55

Notes about This Manual

- The information in this manual is subject to change without notice.
- While meticulous care has been taken in the preparation of this manual, you are requested to notify your dealer or us should you have any comments, views or questions about our product.
- Fully understand the prerequisites to using the product, such as hardware and software specifications and constraints, in using the product. We are not held liable for damages caused by improper handling of the product.
- Reproduction of this manual in whole or in part without our prior written permission is prohibited.
- The product names mentioned in this manual may be trademarks or registered trademarks of their respective owners.

SAFETY INSTRUCTIONS

This Plasma monitor has been designed and manufactured to meet international safety standards, but like any electrical equipment, care must be taken if you are to obtain the best results and safety is to be assured. Before using this product, please read and understand the Safety Instructions thoroughly to ensure correct usage, and follow all the instructions.

About the Symbols

Various symbols are used in this manual, the user's manual and on the product itself to ensure correct usage, to prevent danger to the user and others, and to prevent property damage. The meanings of these symbols are described below. It is important that you read these descriptions thoroughly and fully understand the contents.



This symbol indicates information that, if ignored, could possibly result in personal injury or even death due to incorrect handling.



This symbol indicates information that, if ignored, could result possibly in personal injury or physical damage due to incorrect handling.

Typical Symbols



This symbol indicates an additional warning (including cautions). An illustration is provided to clarify the contents.



This symbol indicates a prohibited action. The contents will be clearly indicated in an illustration or nearby (the symbol to the left indicates that disassembly is prohibited).



This symbol indicates a compulsory action. The contents will be clearly indicated in an illustration or nearby (the symbol to the left indicates that the power plug should be disconnected from the power outlet).



Never use the monitor if a problem should occur.

Abnormal operations such as smoke, strange odor, no image, no sound, excessive sound, damaged casing, elements, cables, penetration of liquids or foreign matter, etc. can cause a fire or electrical shock.

In such case, immediately turn off the power switch and then disconnect the power plug from the power outlet. After making sure that the smoke or odor has stopped, contact your dealer. Never attempt to make repairs yourself because this could be dangerous.



Disconnect the plug from the power outlet.

Do not insert liquids or foreign objects.

Penetration of liquids or foreign objects could result in fire or electrical shock. Use special caution in households where children are present.

If liquids or foreign objects should enter the monitor, immediately turn off the power switch, disconnect the power plug from the power outlet and contact your dealer.

- Do not place the monitor in a bathroom.
- Do not expose the monitor to rain or moisture.
- Do not place flower vases, pots, cups, cosmetics, liquids such as water, etc on or around the monitor.
- Do not place metals, combustibles, etc on or around the monitor.



Do not disassemble.

Never disassemble or modify the monitor.

The monitor contains high voltage components. Modification could result in fire or electrical shock.

- Never remove any fixed cover.

Do not give the monitor any shock or impact.

If the monitor should be shocked and/or broken, it could result in an injury, and continued use could result in fire or electrical shock.

If the glass panel is broken or damaged, immediately turn off the power switch, disconnect the power plug from the power outlet and contact your dealer.



Do not place the monitor on an unstable surface.

If the monitor should be dropped and/or broken, it could result in an injury, and continued use could result in fire or electrical shock.

- Do not place the monitor on an unstable, slant or vibrant surface such as a wobbly or inclined stand.



Do not obstruct the ventilation of the monitor.

If the ventilation is obstructed during the operation of the monitor or just after switching off the power, it could result in damage and shorten the lifespan of your monitor due to overheating. Make sure there is ample ventilation.

- Keep a space of 100mm (10cm) or more between the sides, rear and top of the monitor and other objects such as walls.
- Do not place anything around ventilation openings of the monitor.
- Never block ventilation openings.
- Do not put the plasma screen side up.
- Do not cover the monitor with a tablecloth, etc.
- Do not place the monitor on a carpet or bedding, or near a curtain.



Use only the correct power outlet.

Incorrect power supply could result in fire or electrical shock. Use only the correct power outlet depending on the indication on the monitor and the safety standard.

- The enclosed power cord must be used depending on the power outlet to be used.



SAFETY INSTRUCTIONS (continued)

About the Symbols (continued)



Be cautious of the power cord connection.

Incorrect connection of the power cord could result in fire or electrical shock.

- Do not touch the power cord with a wet hand.
- Check that the connecting portion of the power cord is clean (with no dust), before using. Use a soft and dry cloth to clean the power plug.
- Insert the power plug into a power outlet firmly. Avoid using a loose, unsound outlet or contact failure.
- Do not cut off the fitted power plug, the removal of which could lead to impaired performance. If you wish to extend the lead, obtain an appropriate extension lead or consult your dealer.
- Should you require replacing the fuse in the molded plug with a new fuse, then please replace with new one of the same value, type and approval as the original. Ensure the fuse cover is returned to its original position.



Surely connect the ground wire.

Be sure to keep safety ground connection.

Connect the ground terminal of AC inlet of this monitor with the ground terminal provided at the power outlet using the enclosed power cord. If the provided plug does not fit your outlet, consult an electrician for replacement of the obsolete outlet.

Be careful in handling the power cord and external connection cables.

If you keep using a damaged the power cord or cables, it can cause a fire or electrical shock. Do not apply too much heat, pressure or tension to the power cord and cables.

If the power cord or cables are damaged (exposed or broken core wires, etc.), contact your dealer.

- Do not place the monitor or heavy objects on the power cord and cables. Also, do not place a spread, cover, etc, over them because this could result in the inadvertent placing of heavy objects on the concealed power cord or cables.
- Do not pull the power cord and cables. When connecting and disconnecting the power cord or cables, do it with your hand holding the plug or connector.
- Do not place the cord near the heater.
- Do not touch the power plug just after disconnecting it from the power outlet to prevent electric shock.
- Do not touch the power plug when lightening is close to you.
- Avoid coiling the power cord and bending it sharply.
- Protect the power cord from being walked on, pinched particularly at plugs, conveniences receptacles, and the point where they exit from the apparatus.
- Do not modify the power cord.



Be careful in handling the battery of the remote control.

Incorrect handling of the battery could result in fire or personal injury. The battery may explode if not handled properly.

- Keep the battery away from children and pets. If swallowed consult a physician immediately for emergency treatment.
- Do not allow the battery to be exposed to fire or water.
- Avoid fire or high-temperature environment.
- Do not hold the battery with metallic tweezers.
- Keep the battery in a dark, cool and dry place.
- Do not short circuit the battery.
- Do not recharge, disassemble or solder the battery.
- Do not physically impact the battery.
- Use only the battery specified in the manual of this monitor.
- Make sure the plus and minus terminals are correctly aligned when loading the battery.
- If you observe a leakage of the battery, wipe out the liquid and then replace the battery. If the liquid adheres your body or clothes, rinse well with water.
- Obey the local laws on disposing the battery.



SAFETY INSTRUCTIONS (continued)

About the Symbols (continued)



Be careful in moving the monitor.

Neglect could result in an injury or damage.

- Do not move the monitor during use. Before moving, disconnect the power plug and all external connections.
- You are advised to move the monitor with two persons.
- Avoid any impact or shock to the monitor; particularly take care of glass screen.

Do not put anything on top of the monitor.

Placing anything on the monitor could result in loss of balance or falling, and cause an injury or damage. Use special caution in households where children are present.

Avoid a humid or dusty place.

Placing the monitor in a smoke, a highly humid, dusty place, oily soot or corrosive gas could result in fire or electrical shock.

- Do not place near the kitchen, a humidifier or other place where there is oil, smoke or humidity.

Avoid a high temperature environment.

The heat could have adverse influence on the monitor and other parts, and could result in transformation, melting or fire.

- Do not place the monitor, the remote control and other parts in direct sunlight or near a hot object such as heater, etc.
- Do not put the monitor in a place where the temperature is widely changing.

Remove the power cord for complete separation.

- For safety purposes, disconnect the power cord if the monitor is not to be used for prolonged periods of time.
- Before cleaning, turn off and unplug the monitor. Neglect could result in fire or electrical shock.

Be careful in operating power swivel.

Placing hands or faces near the monitor while operating the swivel function could cause a physical injury or damage. Use special caution in households where children are present.



Disconnect the plug from the power outlet.



PRECAUTIONS

• Installation environment

Do not obstruct a ventilation hole.

Do not put the monitor on carpet or blanket, or near a curtain which has a possibility of obstructing a ventilation hole of the monitor.

Do not put the monitor in the following places.

- Hot places such as near heater, place exposed to the direct rays of the sun.
- A place where the temperature is widely changing.
- Places with soot, dust or high humidity.
- Poor air ventilation place.
- Place near fire.
- A wet place such as bathroom, or shower room.
- Place where you can trip over it.
- Always vibrating or strongly vibrating places.
- Distorted or unstable places.

• How to view the monitor

If you use the monitor in too dark a room, your eyes may become tired.

Please use it in a reasonably bright room.

Avoid direct rays of the sun to the screen in order to prevent eye fatigue.

Your eyes will get fatigued after viewing the monitor for long period of time.

Relax your eyes by viewing away from the monitor from time to time.

Please watch the monitor in downward direction.

• Note on image retention

The plasma monitor illuminates phosphor to display images. The phosphor has a finite illumination life. After extended periods of illumination, the brightness of the phosphor will be degraded to such extent that stationary images would burn-in that part of the screen as grayed-out images. Tips to prevent such image retention are:

- Do not display images having sharp brightness differences or high-contrast images, such as monochrome characters and graphic patterns, for long.
- Do not leave stationary images appearing for long, but try to refresh them at appropriate intervals of time, or try to move them using screen saver function.
- Turn down the contrast and brightness controls.

• How to clean the plasma screen panel of the monitor

Before cleaning the monitor, turn off the monitor and disconnect the power plug from the power outlet.

To prevent scratching or damaging the plasma screen face, do not knock or rub the surface with sharp or hard objects. Clean the screen with a soft cloth moistened with warm water and dry with a soft cloth. If it is not enough, then use a cloth with mild detergent. Do not use harsh or abrasive cleaners.

• How to clean the cabinet of the monitor

Use a soft cloth to clean the cabinet and control panel of the monitor. When excessively soiled dilute a neutral detergent in water, wet and wring out the soft cloth and afterward wipe with a dry soft cloth.

Never use acid/alkaline detergent, alcoholic detergent, abrasive cleaner, powder soap, OA cleaner, car wax, glass cleaner, etc. especially because they would cause discoloration, scratches or cracks.

SAFETY INSTRUCTIONS (continued)

About the Symbols (continued)

• **Prevention of an obstacle to Radio receivers**

This monitor has been designed pursuant to the international EMI standards. This is to prevent a problem to Radio receivers.

- Keep the monitor away from Radio.
- Adjust Radio antennas in order for the monitor not to receive interference.
- The antenna cable of Radio should be kept away from the monitor.
- Use a coaxial cable for antenna.

You can check if this monitor influences Radio receivers by turning off all other equipment other than the monitor.

If you find a problem receiving Radio when using the monitor, check the instructions mentioned above.

• **Precautions for the cable connection**

- Do ensure that all connections, (including the power plug, extension leads and interconnections between the pieces of equipment), are properly made and in accordance with the manufacturers instructions. Switch off and withdraw the power plug before making or changing connections.
- Confirm the connector is fixed tightly when the signal cable is connected.
Also confirm the screws on the connector are tightened.
- Plug the power cord of the monitor into a different socket from that for other equipment, such as Radio etc..
- Use a plug with ground terminal and make sure that it connects to the ground.

• **Precaution during transportation**

Please pay attention when you transport this monitor because it is heavy.

Furthermore, use the original carton box and its packaging materials when the monitor is transported.

Failure to transport the monitor in any carton except the original carton may result in damage to the monitor.

Save the original carton box and all packing material.

Do not physically impact the remote control.

A physical impact could cause damage or malfunction of the remote control.

- Take care not to drop the remote control.
- Do not place heavy objects on the remote control.

Avoid strong rays.

Any strong rays (such as direct sun rays or room lighting) onto the remote control sensors could invalidate the remote control.

Avoid radio interference.

Any interfering radiation could cause distorted images or noises.

- Avoid radio generator such as a mobile telephone, transceiver, etc. around the monitor.

Set the sound volume at a suitable level.

It is better to keep the volume level low and close the windows at night to protect the neighborhood environment.

• **Precautions for the installation**

- Do not use makeshift stands and NEVER fix legs with wood screws - to ensure complete safety, always fit the manufacturers approved stand or legs with the fixings provided according to the instructions.
- Use only with the cart, stand, tripod, bracket, or table specified by the manufacturer, or sold with the apparatus. When a cart is used, use caution when moving the cart/apparatus combination to avoid injury from tip-over.
- This product is designed to comply with the recommended safety standards for tilt and stability. Do not apply excessive pulling force to the front, or top, of the cabinet that could cause the product to overturn resulting in product damage and/or personal injury.
- Follow instructions for wall, shelf or ceiling mounting as recommended by the manufacturer.
- Only use the attachments/accessories specified by the manufacturer.
- Consult your dealer if you are in any doubt about installation, operation or safety of your equipment.

• **Other precautions**

- Do not leave equipment switched on when it is unattended unless it is specifically stated that it is designed for unattended operation or has a stand-by mode. Switch off using the switch on the equipment and show your family how to do this. Make special arrangements for infirm or handicapped people.
- Disposal of this product may require specific instructions pertaining to your resident region.
- Never guess or take any chances with electrical equipment of any kind - it is better to be safe than sorry!

IMAGE RETENTION OF PLASMA DISPLAY

There are different characteristics that result in panel image retention depending on how the plasma display is used. Situations and effective usage methods related to ghosting are provided below.

Image retention characteristics of a plasma display

The image retention phenomenon of a plasma panel occurs due to partial phosphor degradation arising from partial character and figure display.

For example, when the character image as shown in Fig. A at the right is continuously displayed for a long period of time, the only part of the phosphor (Red, Green, Blue) that will degrade will be the color of the applicable character display portion. Consequently, when a white image is displayed on the entire screen as shown in Fig. a, the character marks displayed up to that time will become a color difference visible to the eye, but the phosphor will never burn.

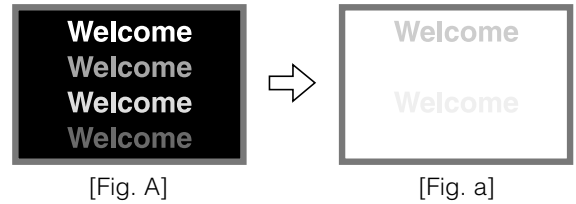

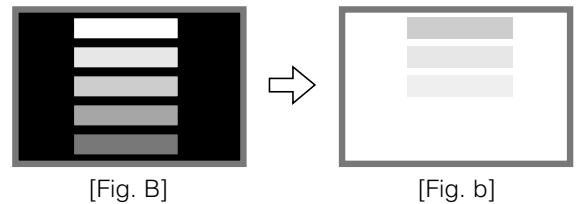

■ The degree of image retention is proportional to the brightness of the characters and figures displayed as well as the display time.

- The tendency of the phosphor is to degrade more the brighter the characters and figures are displayed. When images of figures with different levels of brightness, as shown in Fig. B, are continuously displayed for a long period of time, it becomes easier for image marks at locations when the brighter figures are displayed to be noticeable.



* The image retention images in this document are exaggerated for the purpose of explanation. The actual manner in which the image retention is seen differs depending on the operation time and brightness.

Methods to Reduce the Occurrence of Image Retention

- Lower the Contrast and Brightness settings of the plasma display as much as possible.
A function is provided in the display that controls the brightness of the screen to reduce degradation of the panel. Using this function makes it possible to reduce image retention.
(Refer to Panel Life (Extend 1.or Extend 2) shown on  39)
- Set the plasma monitor to an "Screen Wipe" or "Luminance Manager" display.
The occurrence of image retention when displaying images of identical patterns, such as static images, for long periods of time can be reduced by displaying a completely white screen for about 1 ~ 2 hours after terminating the display. Luminance Manager function works to reduce image retention when displaying images on the four corners, such as TV station logos and clock display.
(Settings can be made using Screen Wipe and Luminance Manager from Function MENU shown on  39)
- Using in combination with moving images
Since the degradation of the fluorescent material progresses comparatively uniform for moving images, the occurrence of partial image retention can be controlled. We recommend to use in combination with moving images such as a DVD.
* Please be careful since image retention will occur if display is left in a two screen display state for a long period of time.
* Television broadcasts include images displayed for long periods of time in which the left and right or top and bottom of the image are cut and broadcast station name or time are displayed for a long period of time at the same portion of the screen. Image retention in these portions can be expected to occur, so please be aware.

Notes

About screen defects

- High precision technology is used in the making of plasma panels but there may be dark spots (points that do not illuminate) and bright spots (points that are too bright) in some cases. These do not indicate a malfunction.

About residual images

- In some cases, residual images may remain after the short-term display of still images and another image is displayed, but these will disappear and return to normalcy. This is not a malfunction.

About the panel screen

- Plasma displays display images by means of electrical discharges inside the panel. Because of this, the temperature of the panel surface may rise in some cases. Also, plasma displays are made of finely processed glass. A reinforced glass filter is installed over the panel surface but avoid strong impact because there is still danger of glass breakage.

About the power swivel

- Do not put hands or faces close to the monitor while operating the swivel function. It could cause a physical injury. Use special caution in households where children are present. (Refer to Power Swivel shown on  25)

COMPONENT NAMES

Main Unit

Front

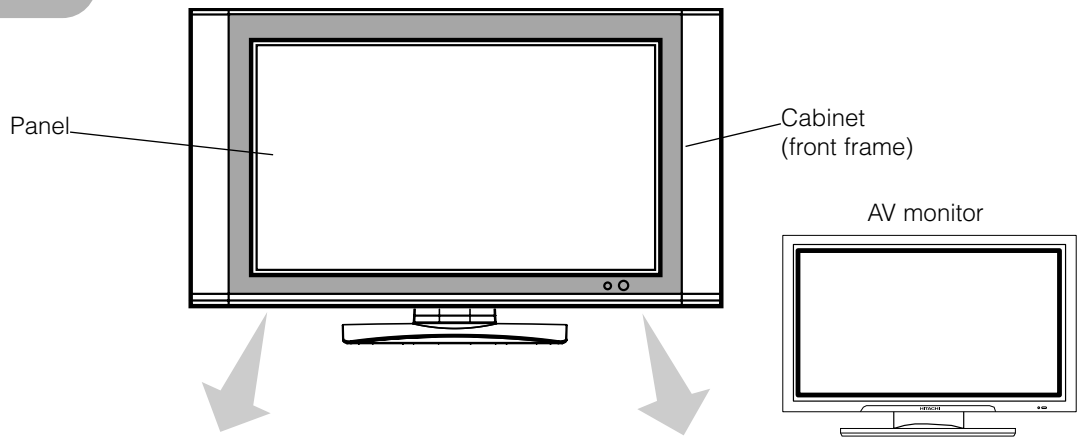

Control panel

- Adjustment buttons are located on the bottom.
- The back cover is provided with indications to distinguish the adjustment buttons.

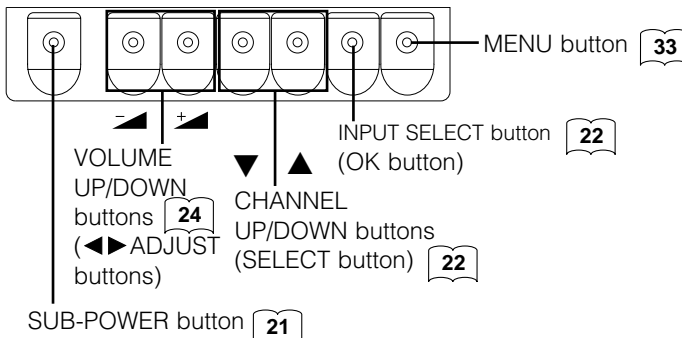
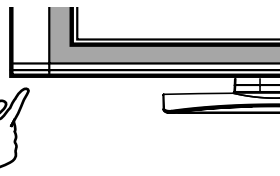

- () indicates the function while the MENU is displayed on the screen.

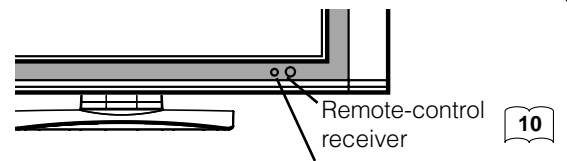

- The main power switch is located at the back, on the lower surface.

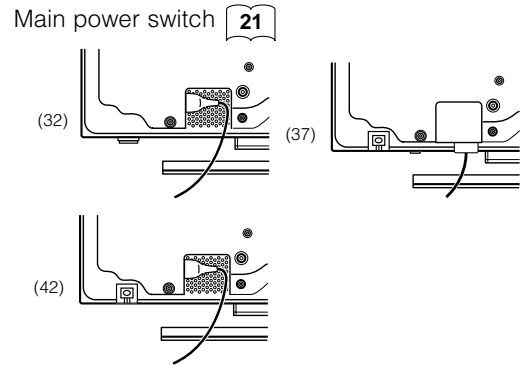

Caution when moving the main unit

- As this product is heavy, whenever it is moved, two people are required to transport it safely.
- Whenever the unit is moved it should be lifted forwards using the two handgrips at the back, and the unit should then be held at the base on both sides for stability.

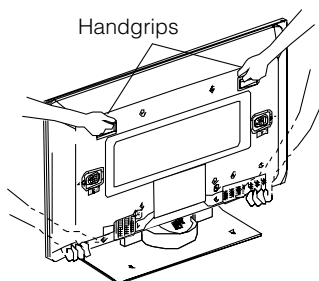

Rear

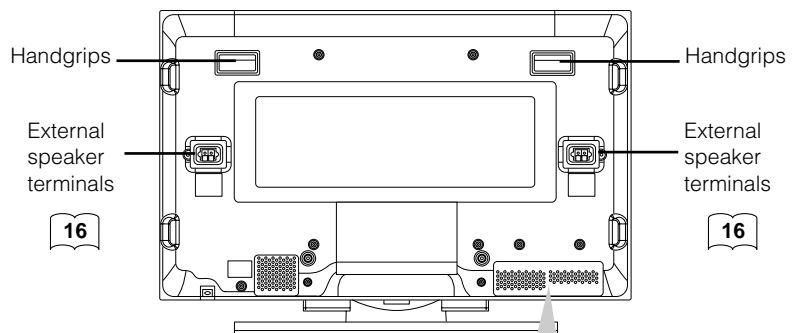

External device connection terminals

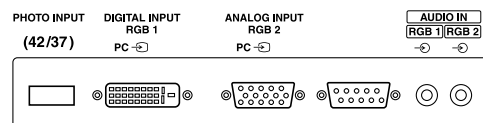

RGB input terminals 16

COMPONENT NAMES (continued)

Remote control

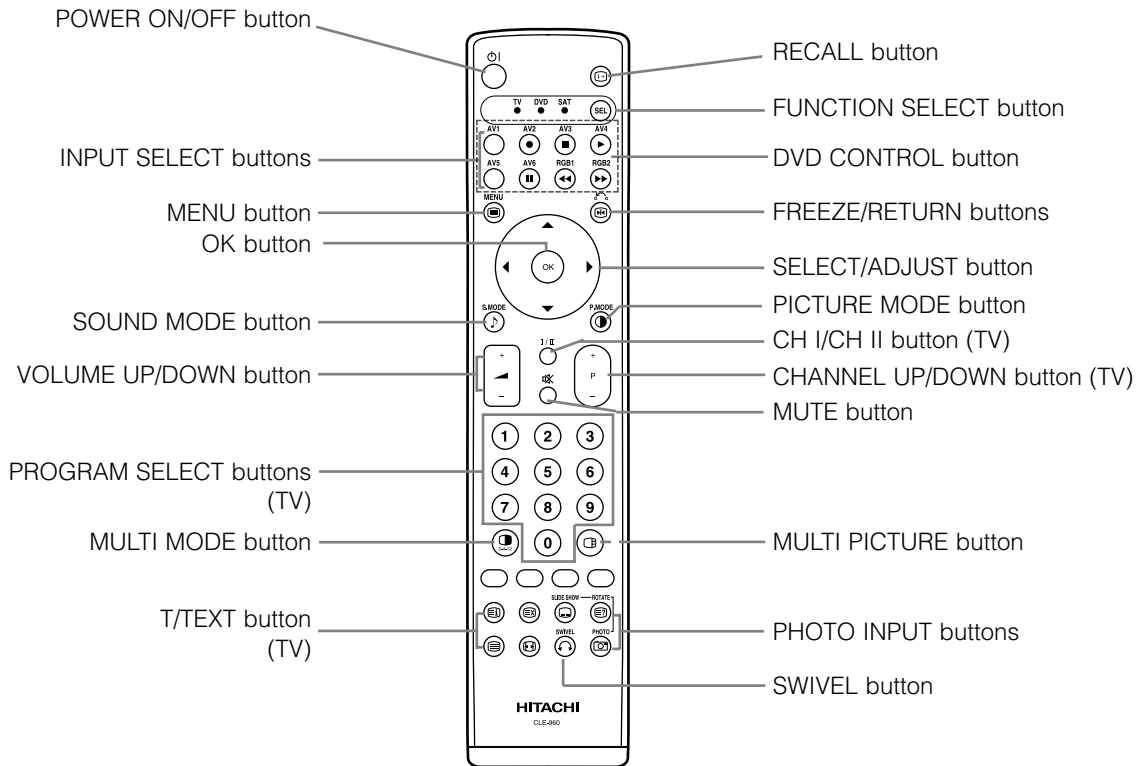

Loading Batteries

1. Open the battery cover.

- Slide back and remove the battery cover in the direction of the arrow.

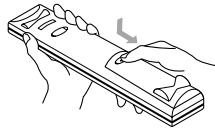

2. Load batteries.

- Load two Size AA batteries included observing the correct polarities.

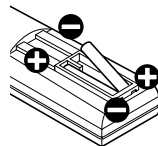

3. Close the battery cover.

- Replace the battery cover in the direction of the arrow and snap it back into place.

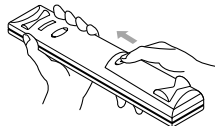

Handling the Remote Control

Use the remote control within about 5 m from front of the unit's remote-control sensor and within 30 degrees on both sides.

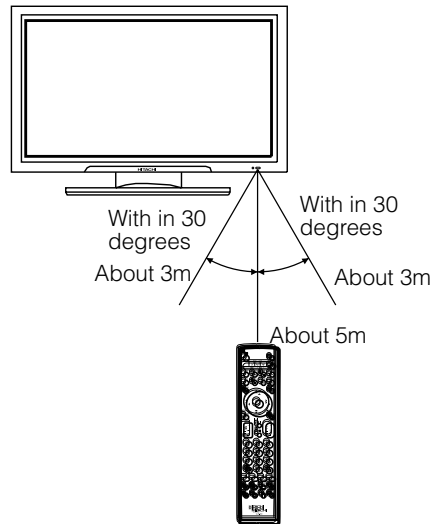

CAUTION

- Do not use new and old batteries together. The batteries could explode or leak, resulting in fires, physical injury, or stains.
- When loading batteries, observe their correct polarities as marked on the product. If loaded in the wrong direction, the batteries could explode or leak, resulting in fires, physical injury, or stains.

ATTENTION

- Do not drop or impact the remote control.
- Do not splash the remote control with water or put it on a wet object to avoid possible failures.
- Before leaving the remote control out of use for an extended period of time, remove the batteries from it.
- If the remote control begins to lack responsiveness, replace the batteries.
- Strong light such as direct sunlight impinging on the photoreceptor of the remote control can cause operational failure. Position this unit to avoid direct contact with such light.

COMPONENT NAMES (continued)

Remote control (continued)

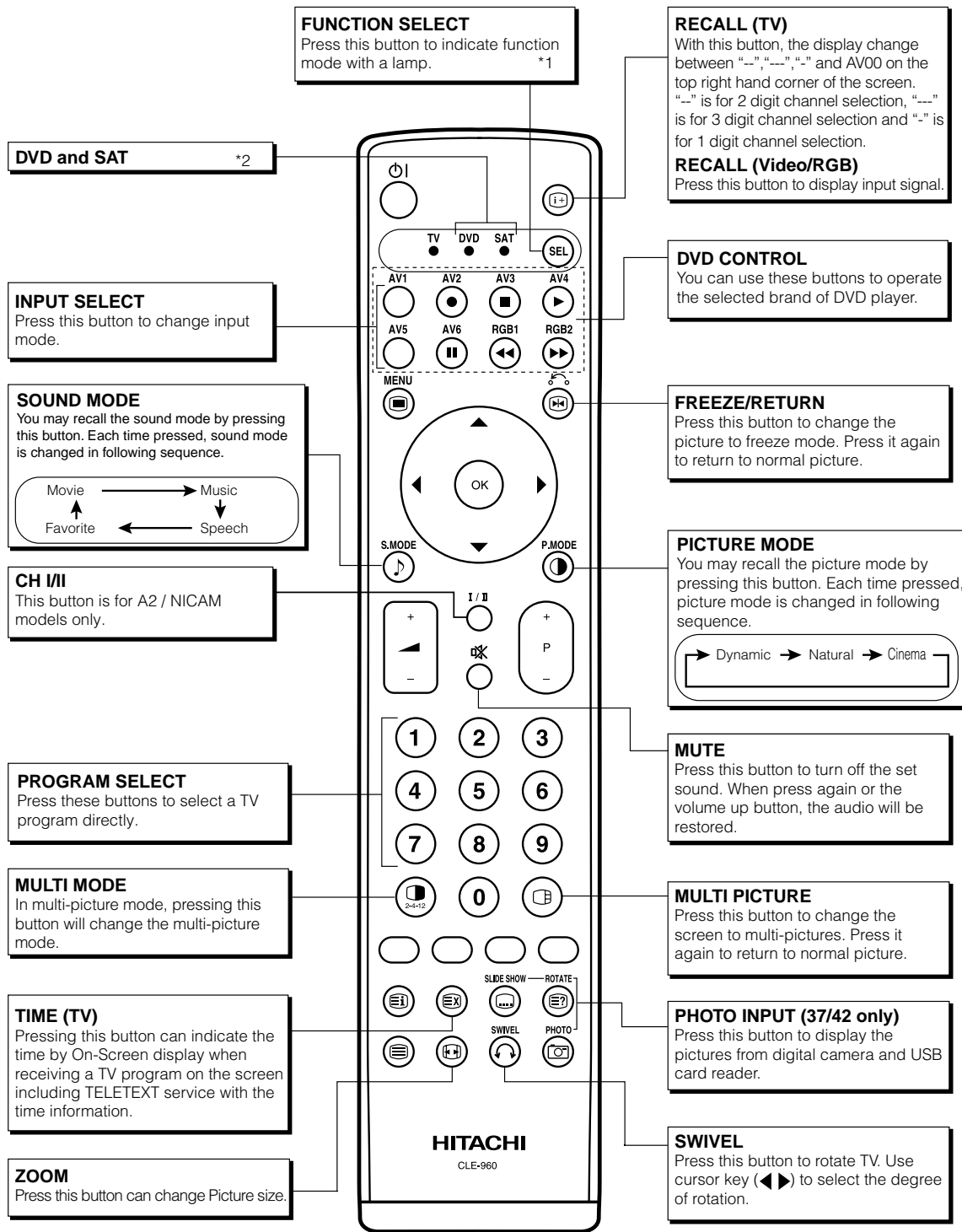

*1 FUNCTION SELECT button

This remote controls has functions to control DVD player, DVD recorder, and STB for certain makers, besides this set. Press **(SEL)** button to operate those equipments. Each time pressed, LED lamps (TV, DVD, SAT) left to **(SEL)** button lights to indicate the selection. For details, refer to **48**

*2 LED

LED lamps of DVD and SAT have 2 conditions (lighting or blinking).
Lighting: Indicate that the corresponding button becomes DVD (STB) mode.
Change to STB (TV) mode when press the **(SEL)** button during LED lighting.
Blinking: Indicate that DVD or STB makers can be set up.
Set up makers/types for DVD or STB during LED blinking (30 sec). For details, refer to **48**
If press the button on the remote control after LED light is off, LED light becomes on the corresponding code.

COMPONENT NAMES (continued)

Remote control (continued)

[Button for TELETEXT Mode]

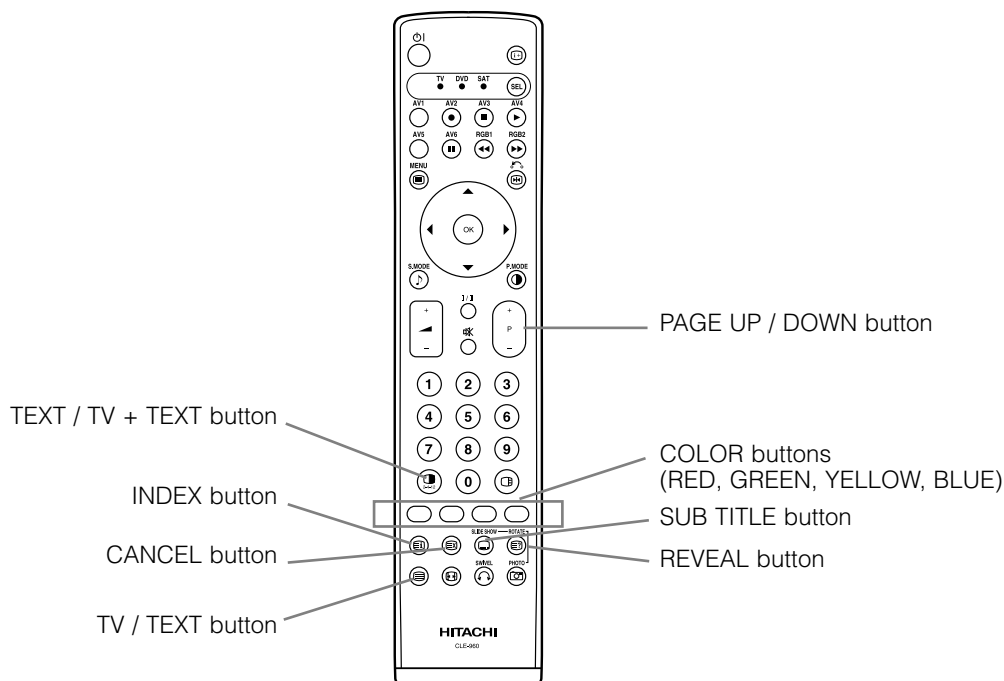

TELETEXT FUNCTION

Buttons on Remote Control	Function
TV / TEXT	This switches the receiver between the TV mode and the TELETEXT mode.
TEXT / TV + TEXT	In TELETEXT mode, this button switches between TV+TEXT screen (split) and TELETEXT only.
INDEX	This selects the P100 (100 page).
SUB TITLE	Use this to access a subtitle service directly rather than through a TELETEXT service (subject to subtitle service broadcasting).
CANCEL	This allows the screen to return to the TV mode temporarily while searching for a required text page. When the required text page has been received, the page number will be displayed at the top left of the screen. Press the CANCEL button again to display the TELETEXT screen.
RED GREEN YELLOW BLUE	Each of these buttons selects a link page displayed at the lower part of the screen.
REVEAL	This allows hidden information (found on some teletext pages) to be displayed on the screen.
PAGE UP / DOWN	These buttons increase / decrease the TELETEXT page number.

NOTE

- Certain pages do not show linked pages at the bottom of the screen. To display linked pages, press the INDEX button.

INSTALLATION INSTRUCTIONS

Installation

⚠ WARNING

Use one of the special mount units to install this product. A mount of insufficient strength or inadequate design can cause overturning or dropping and result in fire, electrical shock or injury. Please note that our company assumes absolutely no responsibility for personal injuries or property damage caused by use of other mount units or improper installation.

⚠ CAUTION

- In order to prevent an internal temperature increase, maintain a space of 10cm (4 inches : For a desktop set-up) or more between the sides and other objects such as walls, etc., so that the ventilation holes are not blocked.(*)

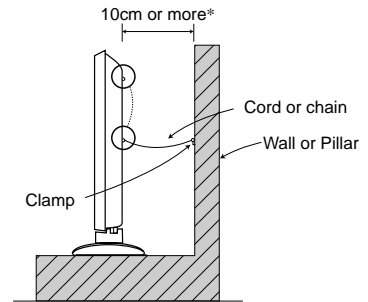

Anti-tumble measures

⚠ CAUTION

Have this unit mounted in a stable place. Take measures to prevent it from tumbling down to avoid possible physical injury.

Securing to a wall or pillar

Using a commercially available cord, chain and clamp, secure the set to a firm wall or pillar.

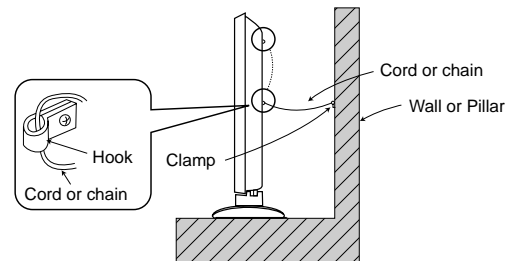

Securing desktop

1) Using wood screws (two), fasten the set to the clamping screw holes on the rear of the stand as shown.

2) Using commercially available wood screws, secure the set firmly in position.

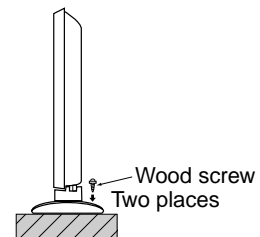

Read SAFETY INSTRUCTIONS (4 to 7) carefully to ensure maximum safety before proceeding to these steps:

- **Choose an appropriate site and install the product on a level table where the stand is secure.**
 - Install the monitor to have ready access to a power socket available.
- **Make sure that the power switch of this device is turned off.**

⚠ CAUTION

Loosen a cord or chain enough while operating power swivel to avoid possible physical injury.

INSTALLATION INSTRUCTIONS (continued)

Connecting to an Audio Visual Device

- (1) Make sure that the power switch of the monitor is turned off.
- (2) Make sure that the power switch of the imaging device is turned off.
- (3) Use a commercially available cable and connector to connect the signal input terminal on the rear panel of this device and the signal output terminal of the imaging device.

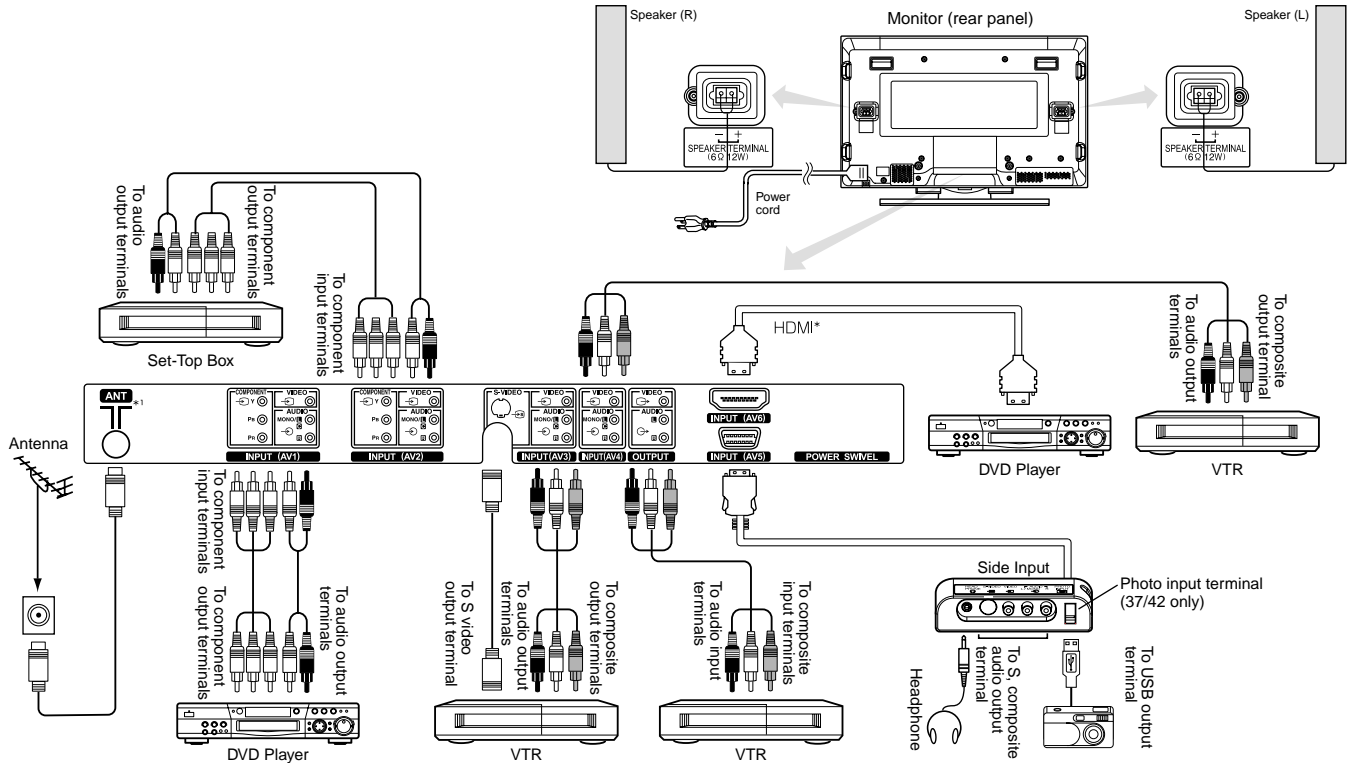

[An example of connecting audio visual devices]

- If a component input terminal and a composite input terminal of AV1 and AV2 connect to the monitor at the same time, component input would govern.
- If a video equipment with an S video output terminal is used, cabling by the S video cable is recommended to provide finer video quality. (If an S video input terminal and a video input terminal of AV3 or AV5 (side input) connect to the monitor at the same time, S video input would govern.)
- If the OUTPUT (Monitor) terminal is connected to an external monitor with a 75 Ohm terminal, it is possible to view the same image as on the main unit. But it is possible to monitor only the composite video signal from AV1 ~ AV5 input or the S video signal from AV3 and AV5 that is displayed on the screen at the time.
- The photo input function might not be provided, depending on a model.
- Secure connecting cables to the stand with the provided clamp.

HDMI*

- HDMI (High-Definition Multimedia Interface) is a digital interface based on DVI (Digital Visual Interface), which is an added function for audio visual equipment.
 - It does not have degradation by transmission since it is digital.
 - With only one cable, it is possible to transmit both picture signals and audio signals.
- In case of using analog audio as connecting with DVI-HDMI transformation connector, use an analog audio terminal for AV1 input.

INSTALLATION INSTRUCTIONS (continued)

Connecting to an Audio Visual Device (continued)

When the "ANT" terminal is connected to outdoor antenna instead of CATV system, please note that a good antenna adaptor is necessary. See the diagram on the right.

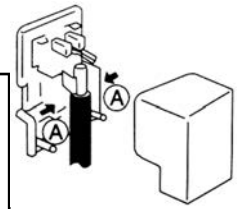

Precautions when connecting the antenna

- Clamp section (A) using pliers when installing the coaxial cable. If other types of adaptors are used, be sure that the core and shielding are good.
- Please use a coaxial cable which is free from interference to connect the antenna. Avoid using a parallel flat feeder wire as interference may occur, causing reception to be unstable and stripe noise to appear on the screen.
- Avoid using indoor antenna as this may be affected by interference. Please use CATV net or outdoor antenna.
- Keep the power cord as far away from the antenna wire as possible.
- For safety, install an external antenna conforming to AS1417.1 (applicable for Australia only)

If there are noise appearance in the picture of VHF-Low band channel, please use the double-shielded cable (not provided) for RF LEADS to reduce the noise.

INSTALLATION INSTRUCTIONS (continued)

Connecting to a PC

(1) Make sure that the display signal of the personal computer to be used is compatible with the specifications of this device.

- See "Product Specifications" concerning the specifications of this device. 53 ~ 57

(2) Make sure that the power switch of the personal computer is turned off.

(3) Connect the signal input terminal (RGB 1 or RGB 2) on the rear panel of this device to the display signal output terminal of the personal computer.

- Use a cable that fits the input terminal of this device and the output terminal of the personal computer.
- Depending on the type of personal computer being connected, the use of an optional conversion adapter or the adapter provided with the personal computer may be necessary in some cases. For details, refer to the instruction manual of the personal computer or ask the personal computer manufacturer or your local retail dealer.

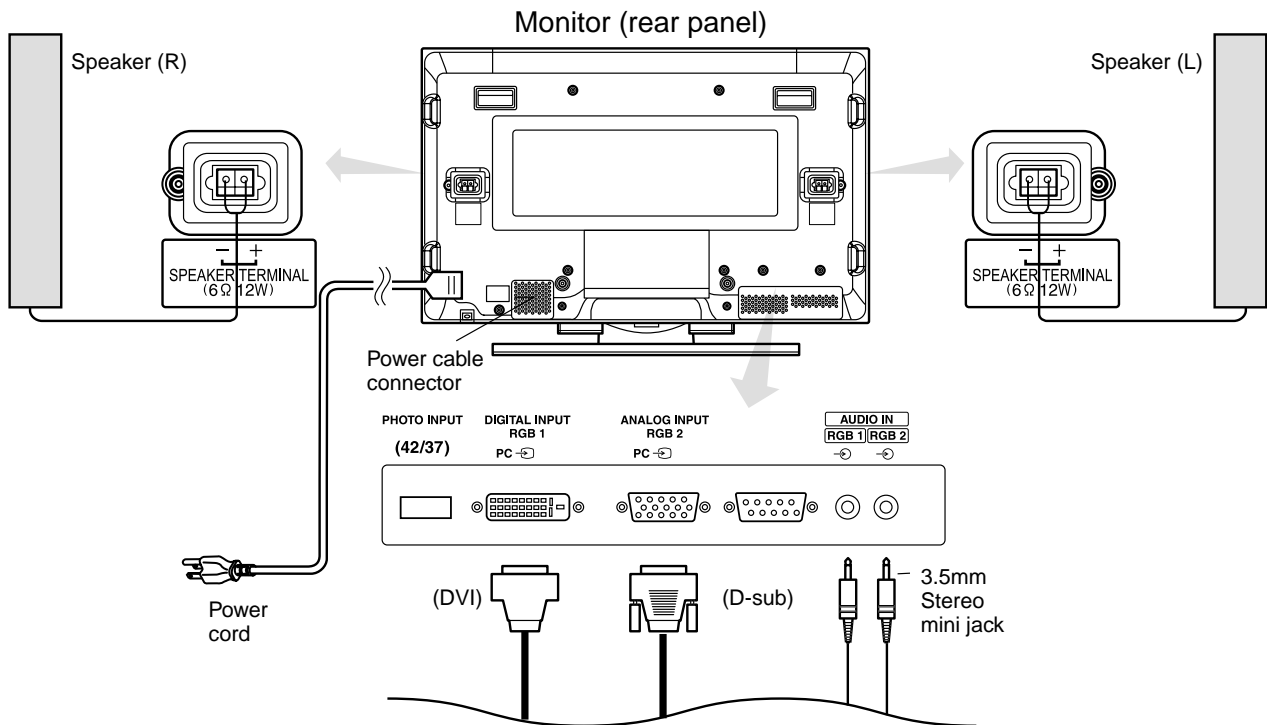

Connecting to a PC Device

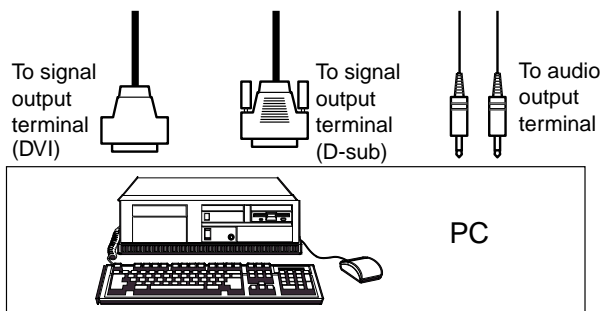

- Setting
 RGB1: DVI-PC
 RGB2: RGB
 For details, refer to 56 ~ 57

Connecting to an Audio Visual Device

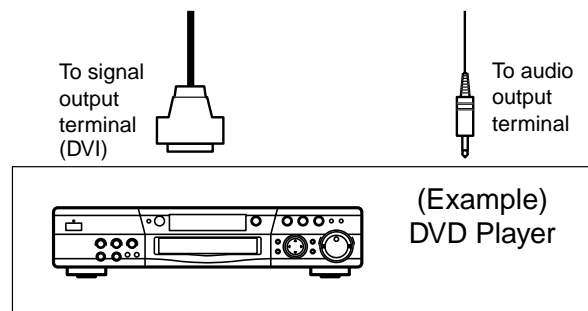

- Setting
 RGB1: DVI-STB
 RGB2: Component
 For details, refer to 55 ~ 56

INSTALLATION INSTRUCTIONS (continued)

Mounting the Speaker Unit



Make sure that the main power switch of the monitor is turned off (standby or indicating lamp: off/red) when removing or connecting the speaker cables.

Mounting the Speaker System to the Monitor

1. Mounting the Speaker System to the Monitor

Hook the clamps (3 pieces) into the holes as shown in the figure, and pull them down.

Follow the step in both Right and Left sides.

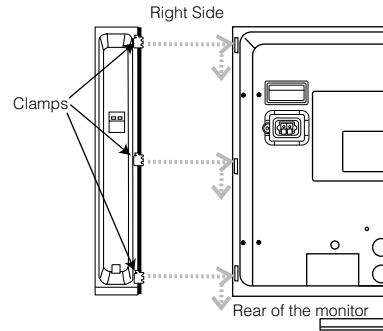

Make sure to use the speaker systems fastened with the speaker holders and the screws.

2. Attach the speaker holders

After twisting the screws off as shown, fasten the speaker system to the monitor with the speaker holder by the screws. The speaker holder direction is opposite on the Right and Left speaker systems.

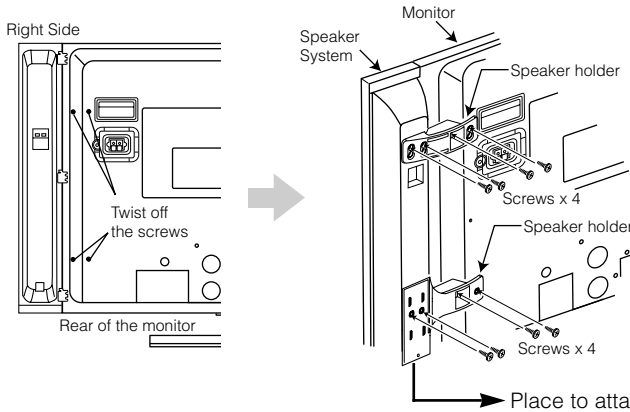

NOTE
In case that the speaker systems do not fit with the monitor body's height.

When loosen the screws fixing the aluminum pieces, the speaker system is movable up and down. Adjust the position to the monitor body's height, then tighten up the screws.

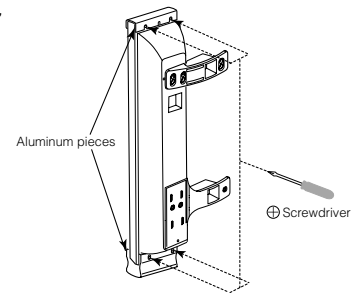

3. Attach the speaker connecting cables to the monitor. (Make sure the ferrite core is toward the monitor side)

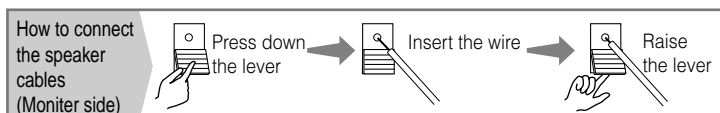
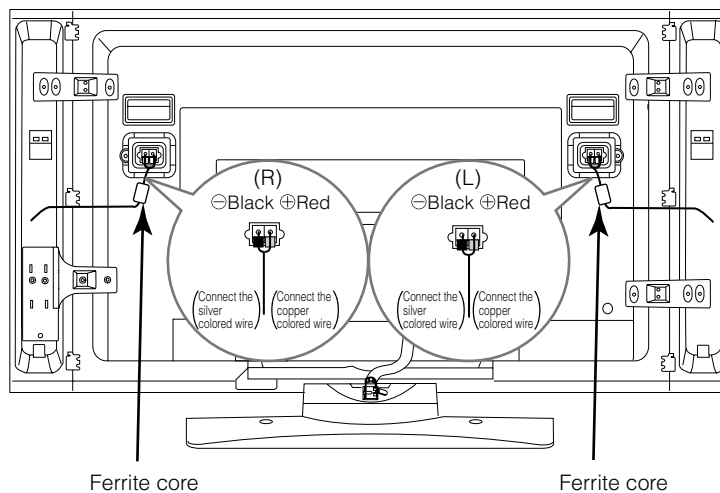
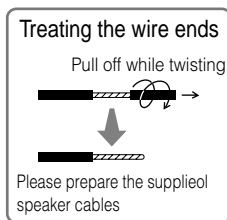

INSTALLATION INSTRUCTIONS (continued)

Mounting the Speaker Unit (continued)

4. Attach the speaker cables to speaker systems.

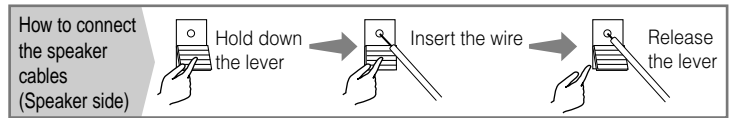
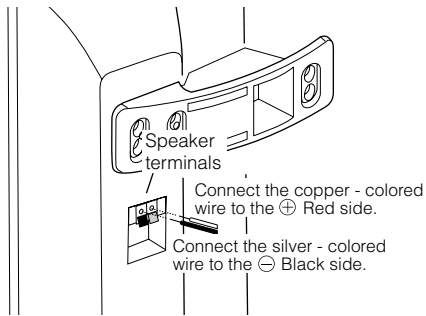

CAUTION

Make sure to secure the power cable and the connecting cables for other audio visual devices, except the speaker connecting cables, to the clamp of the monitor stand and the rear of it. When the monitor is swiveled, the connectors might be dropped out and generate heat. It could cause fire and/or connector failures.

INSTALLATION INSTRUCTIONS (continued)

Mounting the Side Input

• With the speaker unit

1. Mount the side input into the speaker holder.

Hook the clamps (4 pieces) of the speaker holder into the holes as shown in the figure and pull them down until it sounds click.

Fasten the side input with the speaker holder by the screws.

Refer to **14** about the connection of side input.

See the below figure how to treat the cable.

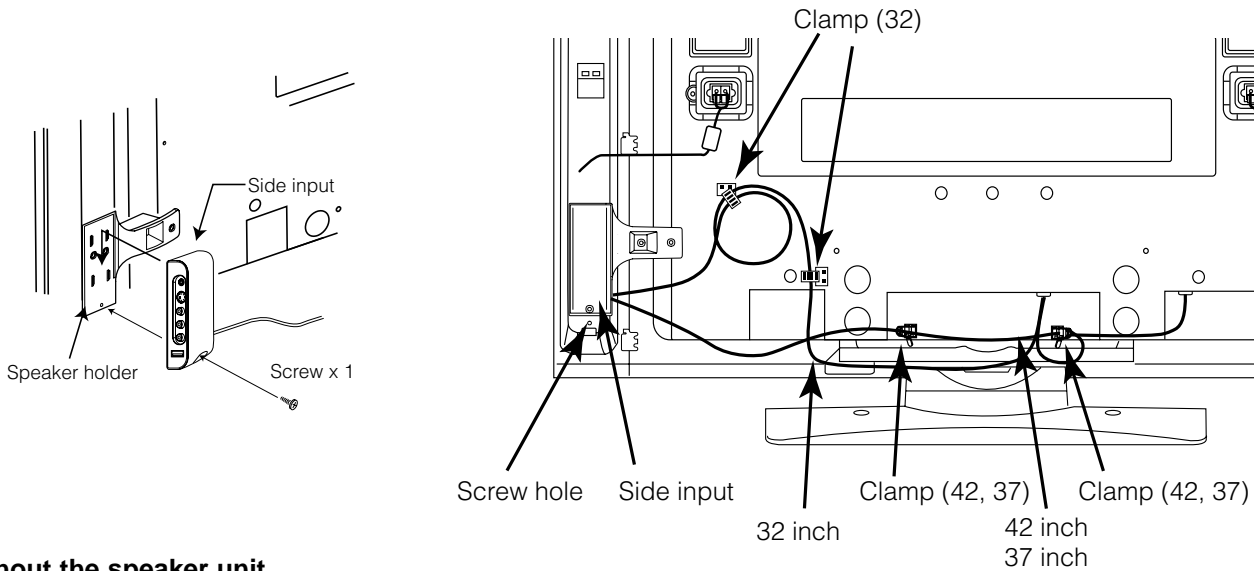

• Without the speaker unit

1. Attach the holder for the side input.

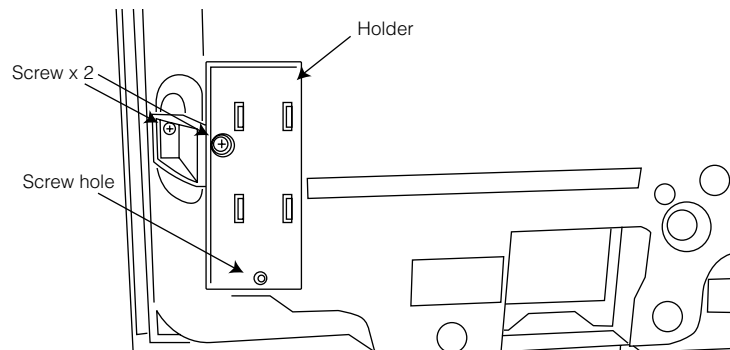

2. Mount the side input into the securing holder.

Fasten the side input with the speaker holder by the screws.

See the below figure how to treat the cable.

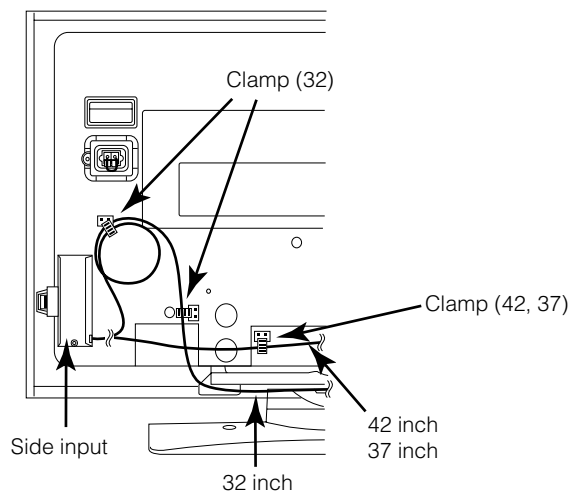

INSTALLATION INSTRUCTIONS (continued)

Power Cord Connection

Connect the power cord, after completing all other connections. ...42, 32

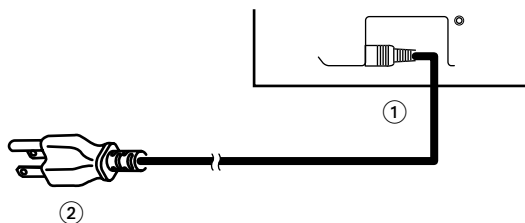

Connect the power cord, after completing all other connections. ...37

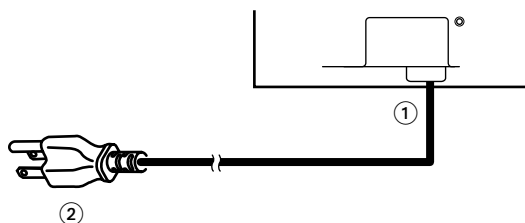

- ① Connect the power cord to this device.
- ② Connect the power cord plug to the power outlet.
(The type of plug is different from this drawing for some countries.)

CAUTION

- Use only the power cord provided. (Ask your local retail dealer about the power cord for AV monitor)
- Do not use a power supply voltage other than that indicated (AC100-240V, 50/60Hz) as this may cause fire or electric shock.

OPERATING INSTRUCTIONS

Turning Power On and Off

- To turn the monitor power ON, press the main power switch on the monitor main unit to ON, and then press the SUB POWER button of control panel or the power button on the remote control.
- To turn the monitor power OFF, press the SUB POWER button of control panel or the power button on the remote control, and then press the main power switch on the monitor main unit to OFF.
 - During normal use, the main power switch is set in the ON position, and the monitor can then be turned ON/OFF using the SUB POWER button or the power button on the remote control.

Indicating lamp

Indicating lamp	Power status	Operating
Off	Off	When the main power switch is set to OFF.
Lights red	Off (standby)	When the main power switch is ON, and the power button on the remote control or the SUB POWER button on the underside of the front of the frame is OFF.
Lights green	On	When the main power switch is ON, and the power button on the remote control or the SUB POWER button on the underside of the front of the frame is ON.
Lights orange	Off (Power Save)	When the main power switch is ON, and the power button on the remote control or the SUB POWER button on the underside of the front of the frame is ON. However, the state in POWER SAVE mode

When the indicating lamp lights in orange or the message "No Sync. Signal", "Power Save" or "Invalid Scan Freq." appears on the screen, there is something unusual about the status of reception. See "Power Save Mode" or "Symptoms That Seemingly Appear to be Failures." **48** **49** **50**

ATTENTION

- Avoid repeatedly turning the monitor on and off at short time intervals. Failures might result from such operation.
- Turn off the main power switch before leaving the monitor out of use for an extended period of time.
- If a power failure occurs while the main unit is running, it would be powered on upon recovery from the failure. Turn off the unit main power switch before leaving the main unit.

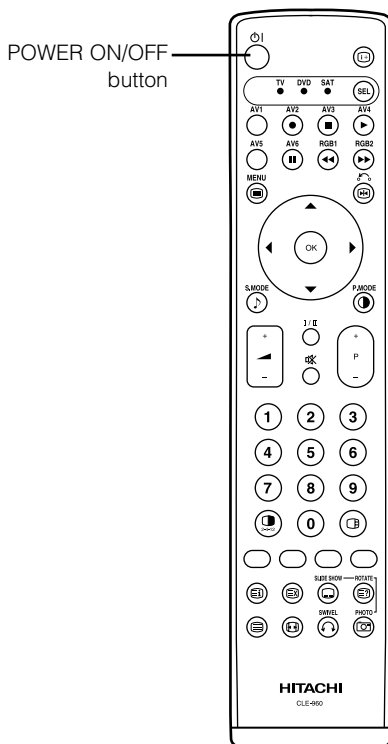
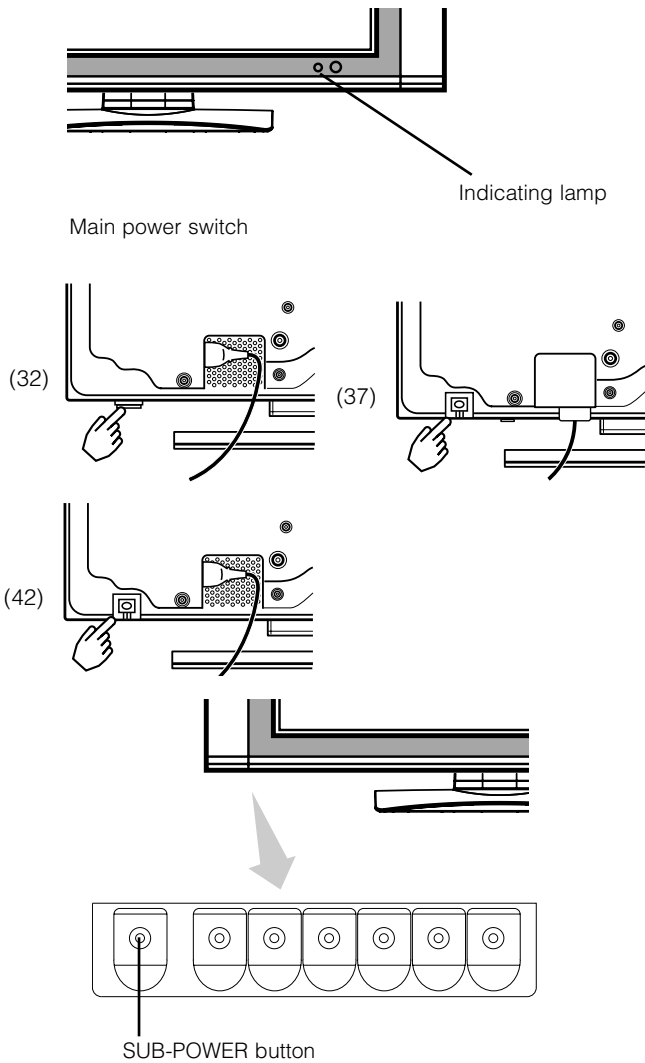

OPERATING INSTRUCTIONS (continued)

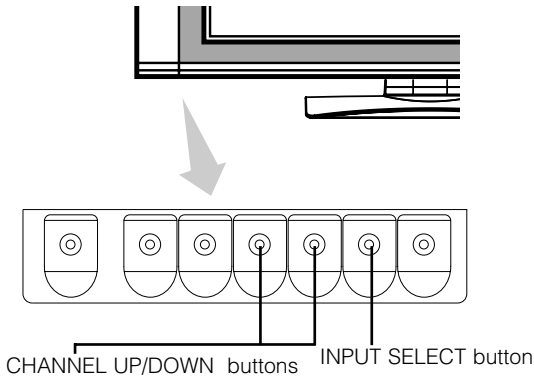

Input Switching

- Input can be switched by pressing the AV1~6, RGB1 or RGB2 buttons of the remote control.
 - Input can be switched to TV by pressing CHANNEL UP/DOWN buttons or PROGRAM SELECT buttons.
 - Input can be switched in the sequence of TV → AV1 → AV2 → AV3 → AV4 → AV5 → AV6 → RGB1 → RGB2 by pressing the INPUT SELECT button of the control panel.
- * TV display is not available in the AV monitor.

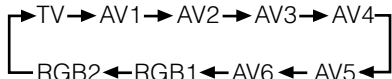

Size Switching

Each time the ZOOM button of the remote control is pressed, the screen display size will change in sequence and the status will be displayed at the bottom of the screen.

- During TV/VIDEO signal input (TV, AV1, AV2, AV3, AV4, AV5, AV6, RGB1 (set to [DVI-STB]) and RGB2 (set to [Component]))

* TV display is not available in the AV monitor.

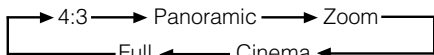

- The size will fix as Full mode and not change when receiving the component signal of 1080i/50, 1080i/60 or 720p/60.



Display size selection diagram

When you want to	Set the display size to	Input signal	Display screen	Remarks
Play a 4:3 image in a 16:9 screen faithfully.	4 : 3			Blanking occurs on both sides.
Play a 4:3 image in a 16:9 screen with the height and width of the middle of the screen enlarged on equal scales and with both sides appearing somewhat enlarged.	Panoramic			
Play a 16:9 VISTA size image in the 4:3 image faithfully reproduced on the 16:9 screen.	Zoom			<ul style="list-style-type: none"> • The 4:3 image is called a letterbox image. • In some cases, some slight blanking may remain at the top and bottom.
Play a 21:9 Cinema size image in the 4:3 image expanded vertically on the 16:9 screen.	Cinema			In some cases, some slight blanking may remain at the top and bottom.
Play a 4:3 image faithfully in a 16:9 screen in the standard vertical size and horizontally squeezed.*	Full			* An image with an aspect ratio of 16:9 shrunk horizontally to 4:3 to display in a 4:3 screen

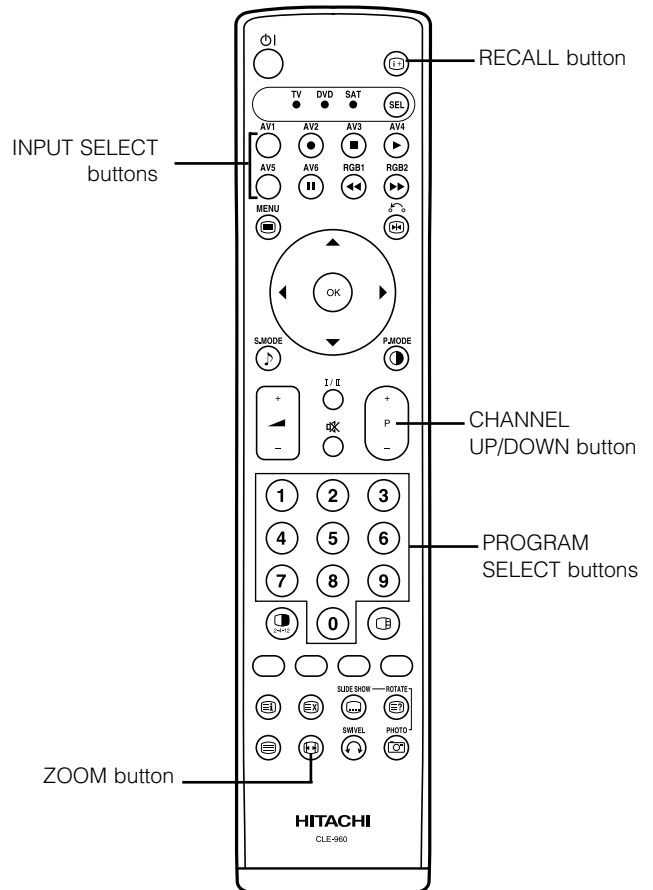

OPERATING INSTRUCTIONS (continued)

Size Switching (continude)

Vertical picture position can be adjusted for [Panoramic], [Zoom] and [Cinema] mode as follows.

1. Press ZOOM button and ▲ ▼ SELECT buttons during picture size display.
2. Position display will appear.
3. Adjustment range of each picture size are as shown below.

[Panoramic]	- 12 to + 12
[Zoom] and [Cinema]	- 31 to + 31
4. When 1080i/60 component signal is received, vertical position can be adjusted only one step up. (The range: 0 to +1)

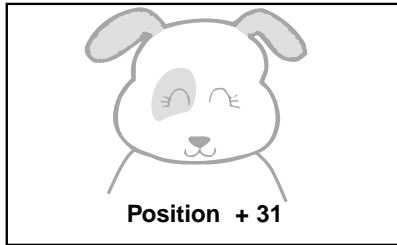

ATTENTION

Using a wide-screen monitor

- This monitor has a screen mode selection feature. If an incompatible screen mode is selected to play certain software, such as a TV program, the image would appear different from the original. Take this into consideration when making screen mode choices.
- Use of this monitor in its enlarged display mode with the wide feature enabled in coffee shops, hotels and other establishments for commercial or pubic viewing purposes could infringe on the copyright holder's right protected by Copyright Law.
- When a normal 4:3 image is displayed over the entire screen in the Panoramic mode, parts of the periphery of the image may disappear and/or appear distorted in some cases. Use the 4:3 mode to view images, which were created in 4:3 mode. This mode allows 4:3 content to be viewed without picture distortion.

• During RGB Input (RGB1 (set to [DVI-PC]) and RGB2 (set to [RGB]))

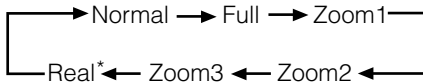

* Real mode gives the image of the same shape as it is displayed on a computer monitor. This mode is only available for VGA (640 X 480) and WVGA (864 X 480).

Display area selection diagram (RGB input)

Resolution	Full display	Circular display				
		Normal	Real	Zoom1	Zoom2	Zoom3
640 X 480 (VGA)						
800 X 600 (SVGA)						
1024 X 768 (XGA)						
1280 X 1024 (SXGA)						
1600 X 1200 (UXGA)						

* VGA and W-VGA only

Processes such as compression (thinning) and expansion are performed for the above signal display. Because of this, there is a possibility that flicker may become noticeable on Zoom (1 ~ 3) depending on the display contents. If this occurs, turning the Vertical Filter On **38** can reduce the flicker.

OPERATING INSTRUCTIONS (continued)

Volume Adjustment

The volume can be adjusted by pressing the **+** and **-** buttons of the remote control (or the **+** and **-** volume buttons of the monitor unit).

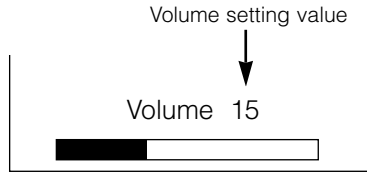

Adjustment status guide display

• **When a button is pressed, the volume adjustment status guide will be displayed.**

- The volume will increase when the **+** button is pressed while the guide is being displayed.
- The volume will decrease when the **-** button is pressed while the guide is being displayed.

Audio Mute

The audio volume can be temporarily mute by pressing the **MUTE** button of the remote control.

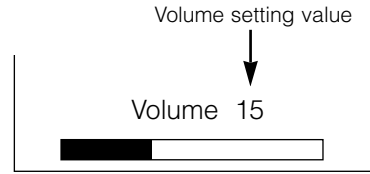

Adjustment status guide display
(The display color will change to magenta: volume → Mute)

• **When a button is pressed, the volume adjustment status guide (magenta) will be displayed.**

- The volume setting can be lowered by pressing the **-** button while the audio is mute.
- The muting can be cancelled by pressing the **+** button or **MUTE** button while the audio is mute.
- The audio from the headphone terminal is not mute.
- The audio from the speaker is automatically mute while connecting the headphone to the headphone terminal of the side input (AV5).

When the MUTE button of the remote control is pressed again, the audio will be restored and the volume display (green) will appear.

OPERATING INSTRUCTIONS (continued)

Power Swivel

- This feature controls the motorized stand. It allows turning the plasma display left or right using the remote control.

CAUTION

Make sure that the main power switch of the monitor is turned off when removing or connecting the power cord, the connector cables, and the speaker cables.

1. Press Swivel button.

The controlling icon appears on the screen.

- If the connecting cable is not connected, the indication "Not Available" appears.
- The swivel display disappears in about 6 seconds without any operation.

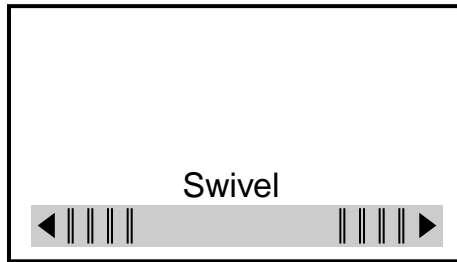

2. Adjust for preferred angle.

Facing directions are displayed on the screen while the monitor is swiveled.

Adjust by using  key while the swivel display is on the screen.

Swiveling angle of the monitor is available within ± 30 degrees from the front face.

ATTENTION

- Do not add excess power by hands while using the power swivel function. It could cause troubles.
- Do not get on and/or hang down the monitor. Do not swing the monitor back and forth and around either. It could cause the failure of the stand.
- Do not put hands or faces close to the monitor while operating the swivel function. It could cause a physical injury. Use special caution in households where children are present.
- Do not put any object, like a vase, near the monitor in swiveling area. It would cause a breakage of the object and /or a failure of the stand.
- Place the monitor on the stable location, or the swivel function would not operate correctly. It would cause the malfunction.
- In the case of using the monitor wall mounted, be sure to detach the connecting cable between the monitor and the stand.

Caution when connecting the monitor with the stand

- When detach the stand from the monitor, make sure to detach the connector cable from the stand connection terminal on the rear of the monitor.

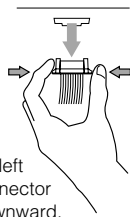

Pinch right and left locks of the connector and pull out downward.

- When attach the stand to the monitor once again, insert the connector cable into the stand connection terminal on the rear of the monitor.

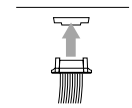

Insert until it clicks.

- Make sure that the direction of the connector for stand connecting cable is correct.

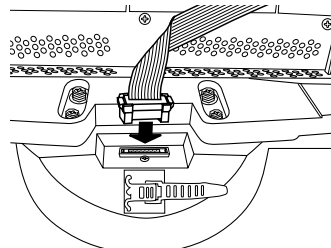
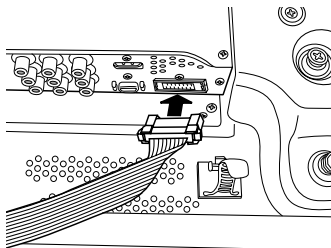

* This power swivel function might not be provided depending on a model.

OPERATING INSTRUCTIONS (continued)

Input Signal Screen Display

The input signal status can be displayed on the screen by pressing the **RECALL** button of the remote control.

- The display will go out in approximately 6 seconds.

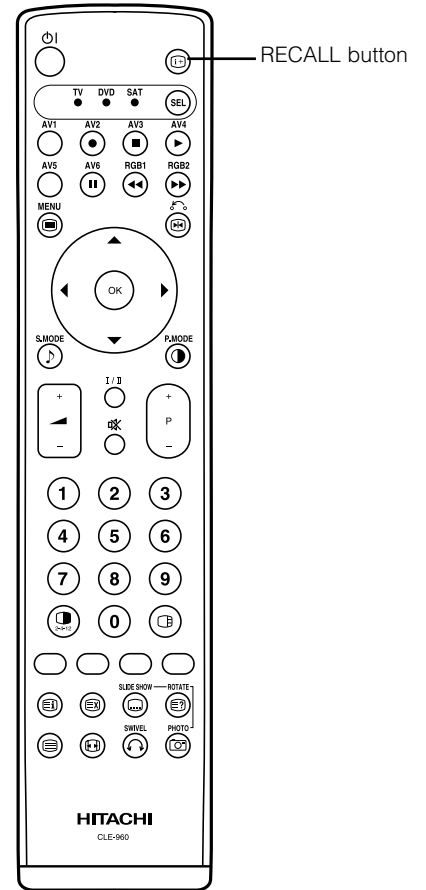
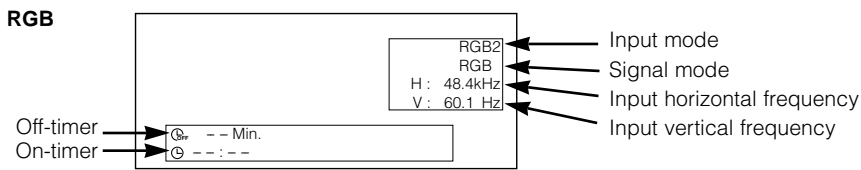
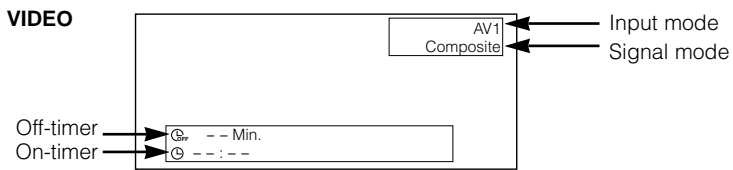
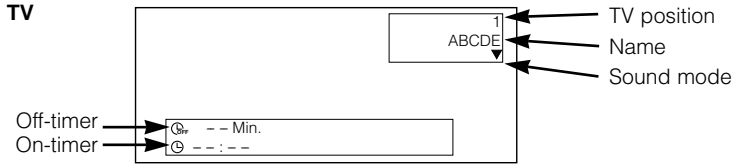

OPERATING INSTRUCTIONS (continued)

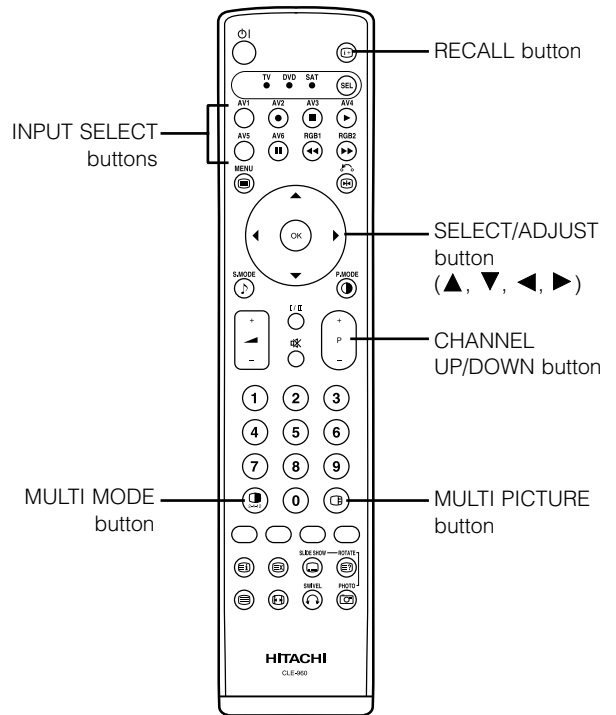

Displaying MULTI PICTURE

If the **MULTI PICTURE** button on the remote control is pressed, multi pictures will display. And then three types of the screen can be selected by pressing the **MULTI MODE** button on the remote control. The multi picture mode will change in the following sequence each time the **MULTI MODE** button is pressed.



Activating the Split mode from the TV screen

Pressing the **MULTI PICTURE** button one time will display 2 pictures.

- The speaker icon can be shifted left and right by pressing the ◀ and ▶ SELECT buttons; the audio will be output from the side on which the speaker icon is located.
- The same signal input cannot be selected for both screens at the same time.
- The TV channel can be changed by pressing the CHANNEL UP/DOWN buttons on the remote control.
- The signal input mode of picture-A or picture-B (the one that the speaker icon is located on) can be selected by pressing INPUT SELECT button on the remote control.
- Pressing the MULTI PICTURE button once again will cancel the multi picture mode.
- Refer to the table for 2 pictures (Split) mode. **28**
- For AV monitor model, TV screen cannot be displayed.

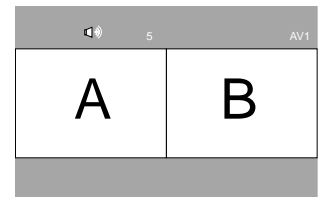

Activating the 4 pictures mode from the TV screen

Pressing the **MULTI MODE** button one time at the 2 pictures mode will display 4 pictures.

- Press ◀ and ▶ SELECT buttons to select picture A or picture B indicated by a red triangle. For pictures on right, press ▲ and ▼ SELECT buttons to select picture. The input display on the selected picture would change green.
- The TV channel can be changed by pressing the CHANNEL UP/DOWN buttons on the remote control.
- The audio can only be output from picture A in 4 pictures mode.
- The component signal input mode cannot be selected in pictures B. Refer to the table for 4 pictures mode. **28**
- Pressing the MULTI PICTURE button at the 4 picture mode will cancel the multi picture mode. And then, pressing the MULTI PICTURE button again will display the 4 pictures.
- For AV monitor model, TV screen cannot be displayed.

▼	AV1	B1 8
A		B2 6
		B3 11

Activating the 12 pictures mode from the TV screen

Pressing the **MULTI MODE** button one time at the 4 pictures mode will display 12 pictures.

- Starting from channel 1, preset channels will automatically display in sequence on the 12 windows.
- This function activates only in TV mode.
- After several seconds, it refreshes the picture one by one.
- Pressing the MULTI PICTURE button at the 12 picture mode will cancel the multi picture mode. And then, pressing the MULTI PICTURE button again will display the 12 pictures again.
- Pressing the MULTI MODE button at the 12 picture mode will display the 2 pictures (Split) mode.
- This function is not provided for AV monitor model.

1	2	3	4
5	6	7	8
9	10	11	12

OPERATING INSTRUCTIONS (continued)

Displaying MULTI PICTURE (continued)

Activating the Split mode from the video input screen

Pressing the MULTI PICTURE button one time will display 2 pictures.

- The speaker icon can be shifted left and right by pressing the ◀ and ▶ SELECT buttons. The audio of the video will be output from the side on which the speaker icon is located.
- The same video input mode cannot be selected for both screens at the same time.
- Pressing the MULTI PICTURE button again will cancel the 2 pictures display.
- Refer to the table for 2 pictures (Split) mode.

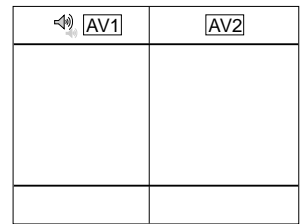

Activating the MULTI PICTURE mode from the RGB input screen

Pressing the MULTI PICTURE button one time will display 2 pictures.

- This mode can be available from RGB1(DVI-PC) and RGB2(RGB) input.
- The speaker icon can be shifted left and right by pressing the ◀ and ▶ SELECT buttons. The audio of the video will be output from the side on which the speaker icon is located.
- The sub-screen position can be selected up and down by pressing ▼ and ▲ SELECT buttons.
- The sub-screen can be selected with the AV1~AV6, TV channel buttons from the status that the speaker icon appears on the left side of AV* etc. as shown in the diagram to the right.
- Pressing the MULTI PICTURE button again will cancel the 2 pictures display.
- "Frequency Mode" in the Setup Menu should be set to Movie when sub-screen is the component signal of 1080i/50 or 1080i/60.

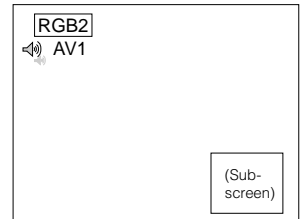

AV1: Displays the VIDEO input signal of the sub-screen.

NOTE

- Even if the input of the horizontal / vertical synchronizing signal (or video signal) stops in the multi picture display, the mode will not change to power save mode.
- Please be careful since image retention will occur if display is left in a multi picture display state for a long period of time.

2 Pictures (Split)

Input terminal			AV1~AV5				AV1, AV2, AV6			RGB1	RGB2	TELE TEXT	
	Main	Sub	TV	PAL SECAM	NTSC3.58 NTSC4.43	576i 576p	480i 480p	1080i/50	1080i/60	720p/60	STB		Component
		TV	○	○	○	○	○	○	○	○			○
AV1 ~ AV5		PAL, SECAM	○	○	○	○	○	○	○	○			
		NTSC3.58/4.43	○	○	○	○	○	○	○	○			
AV1		576i, 576p	○	○	○	○	○	○	○	○			
		480i, 480p	○	○	○	○	○	○	○	○			
AV2		1080i/50	○	○	○	○	○	○	○	○			
	AV6	1080i/60	○	○	○	○	○	○	○	○			
		720p/60	○	○	○	○	○	○	○	○			
RGB1		STB											
RGB2		Component	○	○	○	○	○	○	○	○			

(○ : Available)

Teletext is available only for TV

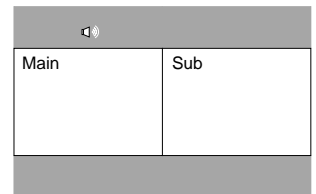

4 Pictures

Input terminal			AV1~AV5				AV1, AV2, AV6			RGB1	RGB2	TELE TEXT	
	Main	Sub	TV	PAL SECAM	NTSC3.58 NTSC4.43	576i 576p	480i 480p	1080i/50	1080i/60	720p/60	STB		Component
		TV	○	○	○								
AV1		PAL, SECAM	○	○	○								
		NTSC3.58/4.43	○	○	○								
AV1		576i, 576p	○	○	○								
		480i, 480p	○	○	○								
AV2		1080i/50	○	○	○								
	AV6	1080i/60	○	○	○								
		720p/60	○	○	○								
RGB1		STB											
RGB2		Component	○	○	○								

(○ : Available)

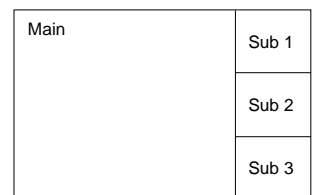

OPERATING INSTRUCTIONS (continued)

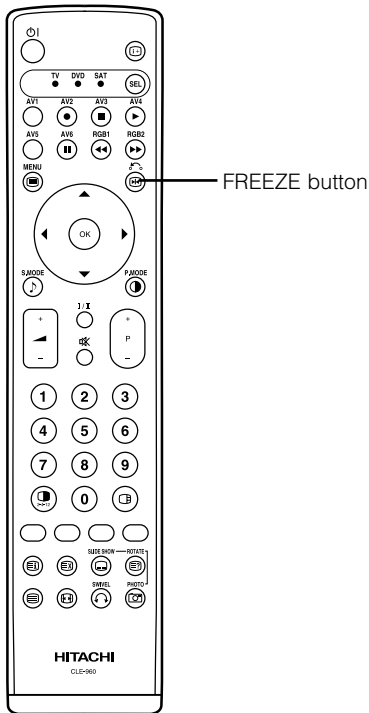

Picture Freezing

When the FREEZE button on the remote control is pressed, the screen transfers into the freeze mode.

- There are two types of freezing screen mode, Split and Strobe. These are possible to select at the "Freeze Mode" setting of the Function Menu.
- The Split mode will display 2 pictures from the same source on the screen with one active picture and the other still.
- The Strobe mode will display 12 pictures with the last picture active, while other 11 windows are still.
- Pressing the FREEZE button again changes the screen back to the normal picture.
- This function is also available from video input mode besides TV mode. Refer to the table for Freeze function as below:

	Split	Strobe
TV	○	○
PAL, SECAM	○	○
NTSC3.58/4.43	○	○
576i	○	○
480i	○	○
576p	○	
480p	○	
1080i/50	○	
1080i/60	○	
720p/60	○	
RGB, DVI-PC		

(○ : Available)

[Split]

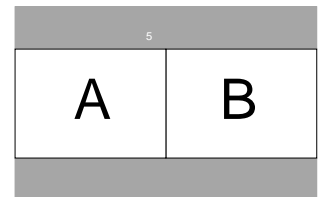

[Strobe]

1	2	3	4
5	6	7	8
9	10	11	12 Active

OPERATING INSTRUCTIONS (continued)

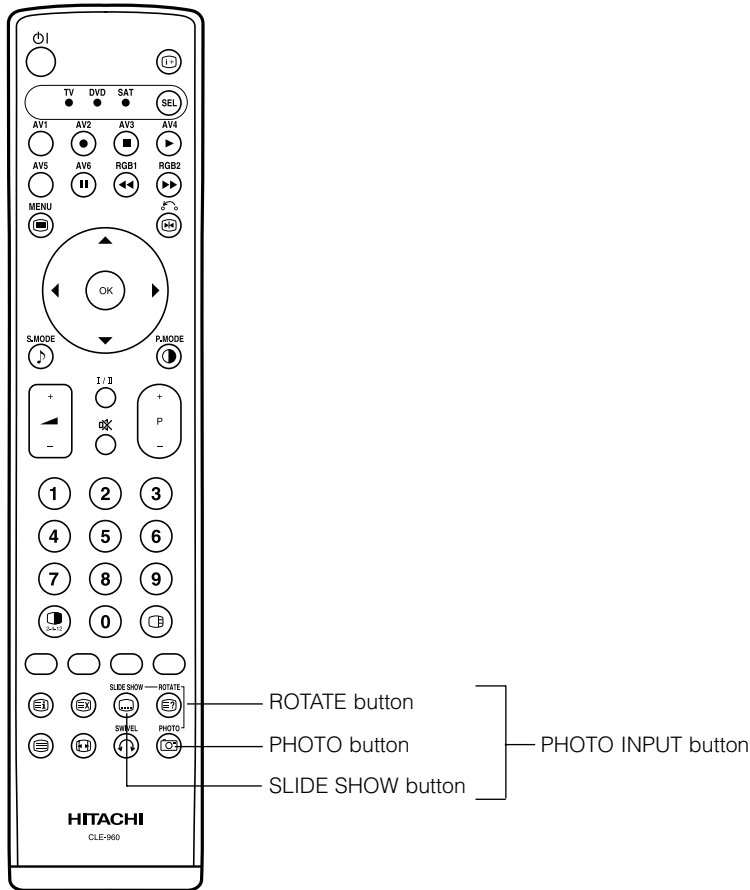
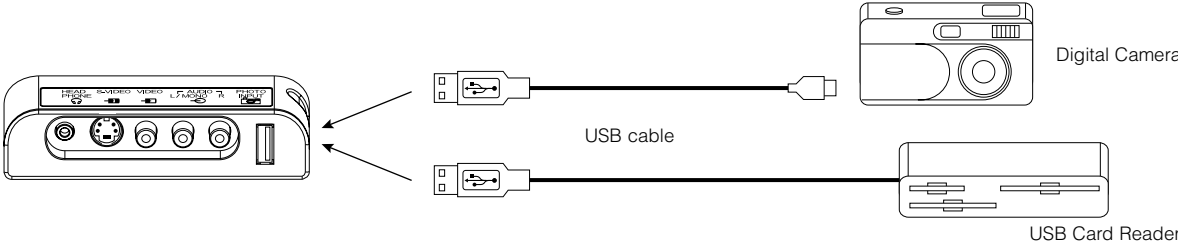

Photo Input Display (37/42 only)

With the PHOTO button on the remote control, the pictures from a digital camera or Card Reader can be displayed.









Operating the Photo Input

1. Make sure that the power switch of the monitor is turned off/standby before using.
2. Set up the digital camera and its power in reference to the item relating to "connecting to PC" on the user manual of digital camera.
*Insert the memory card when use the USB Card Reader.
3. Connect the monitor with the USB cable (see the above picture). Switch the input to the photo input by pressing PHOTO button. Then, turn on the power of the digital camera.
(Refer to the user manual of your digital camera).
4. The photo pictures will be displayed after a period of time turning on the camera, if connecting normally.

OPERATING INSTRUCTIONS (continued)

Photo Input Display (37/42 only) (continued)

Photo Input Function

Buttons on Remote Control	Function	Operating
PHOTO 	Display the pictures in the thumbnail view. Return to the previous input display during the thumbnail or the full view.	Thumbnail-Size Image <ul style="list-style-type: none"> • Select the pictures by using (▲ , ▼ , ► , ◀) key. • Display the next or previous thumbnail-view of 16 images per one page by using (+), (-). • Display the selected picture in the full size by pressing  button. Full-Size Image <ul style="list-style-type: none"> • Return to the thumbnail-view by pressing  button or return button.
ROTATE 	Press this to display the picture with rotate mode.	<ul style="list-style-type: none"> • Each time pressed, the picture is rotated in the sequence of 90° → 180° → 270° → 0°.
SLIDE SHOW 	Press this to display the slide show of pictures.	<ul style="list-style-type: none"> • Press the button while displaying the picture, the slide show begins from the first picture at a fixed interval. • Press OK key, the slide show will be paused with OSD display [start]. The slide show starts if let the condition for a minute. • Return to the thumbnail images when finishing the all of pictures. • Interval time during slide show can be changed from 5, 10 and 30 seconds in "Slide Interval" of function menu. 

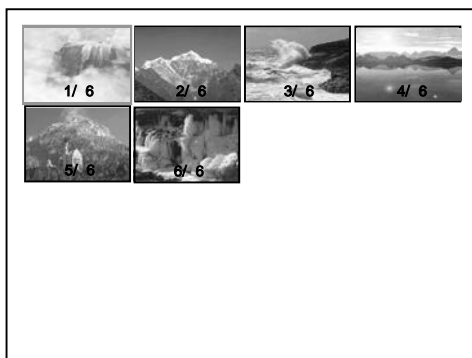

Thumbnail-Size Image

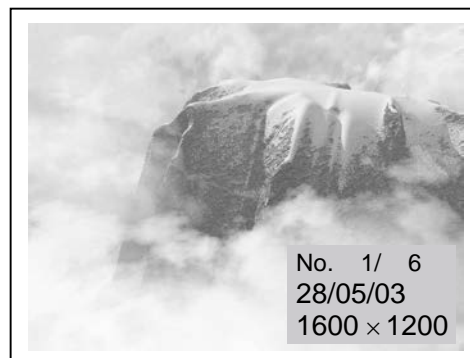

Full-Size Image

• Specification

Application	① Digital Camera corresponding to DCF standard. ② USB Card Reader with the memory containing pictures had taken by ① camera.
Max number of picture	500
Max number of pixel	8176 x 8176 JPEG format

• Error Information

PHOTO INPUT	Information
Accessing	No message
Normal	No message
Not insert USB	"No Connection"
Not available format	"No Connection"
Abnormal	"No Connection"
No File	"No File"
Loading Files	"Loading"

OPERATING INSTRUCTIONS (continued)

Photo Input Display (37/42 only) (continued)

CAUTION

- The picture may not be displayed in case of editing by computers.
- Do not connect any apparatus other than a digital camera and a USB card reader to the photo input connector. It causes the malfunction.
- Do not connect a digital camera and USB card reader with USB HUB. Pictures may not be displayed correctly, or it causes the malfunction.
- Insert only one memory even though the USB card reader has multiple slots for memory card. Pictures in multiple memory cannot be seen at the same time.
- Certain types of digital cameras or card readers may not work with this photo input function.
- Digital cameras with low battery power may not properly display photos in this input.
- This function does not work for audio and moving images taken other than a digital camera.
- Response time might vary according to each image content when switching pages.
- Contrast will decrease automatically if stationary images such as digital still photos are left on the screen for more than 3 minutes.
- The OSD message "No Connection" is displayed in case of the incomplete connection with USB cable and connection to a digital camera or USB card reader without the memory card.
- The menu items other than "Picture" and "Function" are not available with grayed-out display.
- The functions of the multi picture, CH selection, freeze mode, aspect, mode display, and so on are not available.
- During blinking LED which indicates the access of a digital camera or USB card reader, or displaying "Loading", do not turn the power off/standby mode nor remove/insert USB cable and memory card.
- The picture may not be displayed correctly, depending on the connecting device in case of extending the USB cable.

* This photo input function might not be provided depending on a model.

OPERATING INSTRUCTIONS (continued)

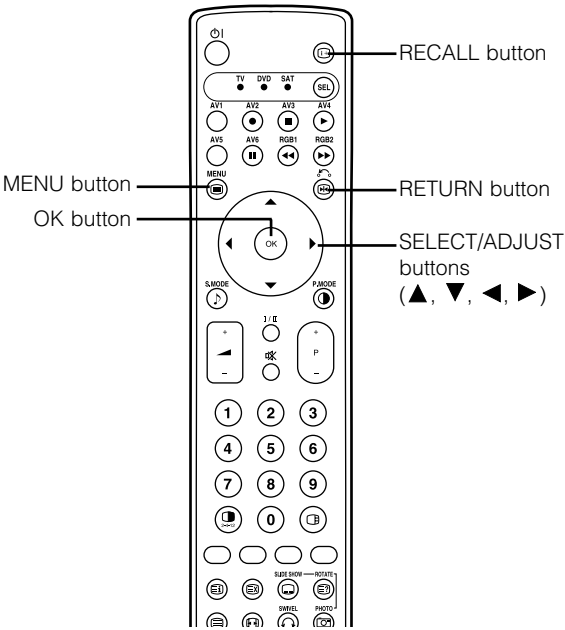

Using the Menu Screen (On-screen display system)

When the MENU button is pressed, the adjustment menu screen will be displayed; from there, PC signal adjustment and setting is possible by using the SELECT button, ADJUST button and OK button.

- Refer to 34 - 46 concerning the adjustment items and the settings.

Example: Selecting the Picture screen

1. Press the MENU button to display the Main Menu screen.

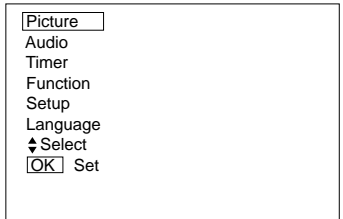

2. Press the OK button to display the Picture Menu screen. (Use the ▲ and ▼ SELECT buttons to select other items.)

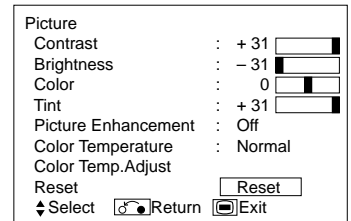

3. Use the ▲ and ▼ SELECT buttons to select the item to be adjusted and then use the ◀ and ▶ ADJUST buttons to adjust (example: Contrast).

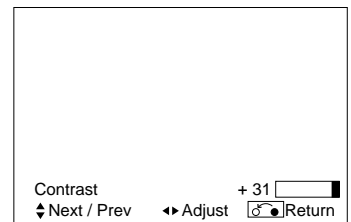

- Press the RETURN button to return to the previous screen.
- If there is no operation for a period of one minute, the Adjustment Menu screen will be closed automatically.

OPERATING INSTRUCTIONS (continued)

SETUP MENU (TV mode) (continued)

Selected characters	◀	▶	Setup hint
Auto Tuning			
Mode			Select the channel entry method between position setting or direct setting. And press the OK button to fix it. <ul style="list-style-type: none"> • If [Position] is selected, the screen display will be numbers (1~199 and AV00). • If [Direct] is selected, the screen display will be C** at the channel 0~99 and S** at the channel 100~199.
Search	-	-	Press the OK button and it starts the auto tuning.
Manual Tuning			
Position	-	-	Set the position number(0~199) or channel number(C**, S**) by (+) (-) CHANNEL UP/DOWN buttons.
Frequency	-	-	<ul style="list-style-type: none"> • If [Position] has been selected, search the frequency here by pressing ◀ and ▶ buttons. • If [Direct] has been selected, this function will be not available (grayed out).
Name			This is used to input the name of the TV station within 5 letters. After fixing the cursor on the first digit, select a letter by ▼ and ▲ SELECT buttons and move to next digit by ▶ ADJUST button. Press the OK button again after finished. <ul style="list-style-type: none"> • Selectable letters are "0"~"9", "A"~"Z", "+", "-", " "(blank), ",", "(comma) and "."(period) .
Sound System			Select the sound system through the 5 different settings.
Color System			Select the color system through the 5 different settings.
Skip			If this is set to On, that position will be skipped while selecting positions by CHANNEL UP/DOWN buttons. This is automatically set to On for those non-broadcasting channels.
NR			If this is set to On, it helps to reduce the noise interference visible on the screen, especially in the weaker signal reception areas.
Antenna Att.			If this is set to On, it helps to reduce the noise interference visible on the screen in case of strong airwave.
Fine Tuning	Decreasing the frequency data for the main tuner	Increasing the frequency data for the main tuner.	After completing the fine-tuning, press the RETURN button to exit this mode. <ul style="list-style-type: none"> • The variable range is -56 ~ +56.
Sort	(When the Mode in Auto Tuning menu is set to [Direct], this function will be not available (grayed out).)		
(A Line of position List)	-	-	Press OK button at the a line that is required to change order, then the characters will change to green. And move it up or down in the list by pressing ▲ and ▼ SELECT buttons. And press OK button to complete it. Press the RETURN button to exit.
Teletext Language	-	-	Select the teletext language through the 4 settings. <ul style="list-style-type: none"> • Select West Europe when watch in Singapore, Australia, Malaysia, and so on.
Auto Off			If this is set to On, the power will be turned off when there is no transmission signal and no operation for about 10 minutes in the TV mode.

OPERATING INSTRUCTIONS (continued)

SETUP MENU (Video mode)

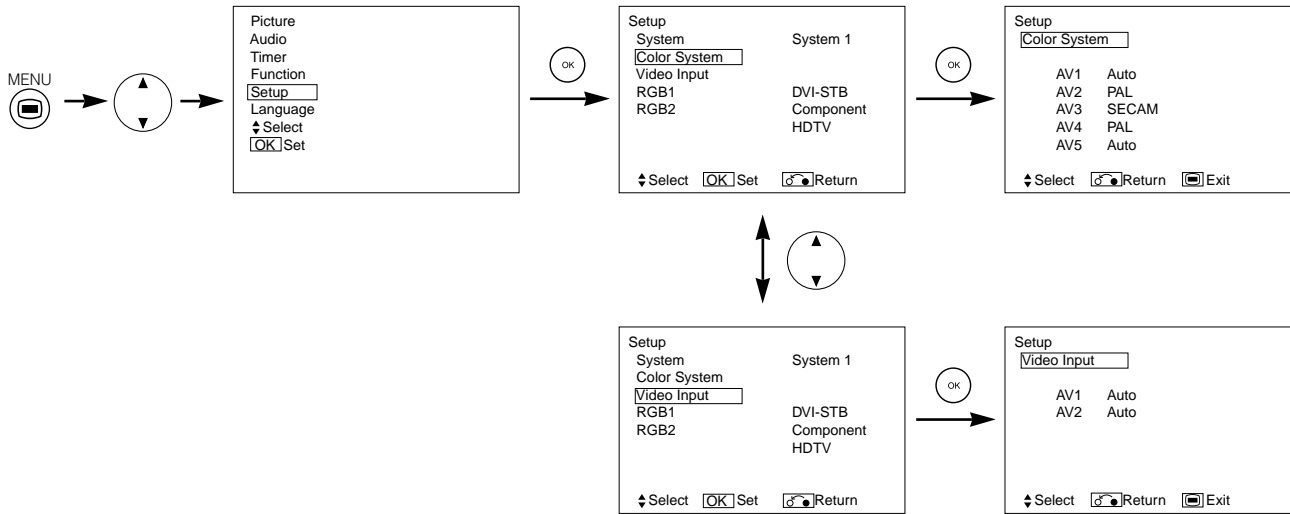

Selected characters	◀ ▶	Setup hint
System	System1 ↔ System2	Do not change the original setting. (System1 : Europe/Asia, System2 : North America)
Color System		
AV1~AV5	System1 Auto ↔ PAL ↔ SECAM NTSC3.58 ↔ NTSC4.43 System2 Auto ↔ NTSC-M PAL-N ↔ PAL-M	This should correspond to the color system of the signal from the equipment that is connected to AV1~AV5 video input terminal. • Normally, set this to Auto. The system of the input signal will be automatically recognized. • If the input signal contains much noise or has a low level at Auto and the operation is found erratic, set this to match the input signal. • When the component signal is received, this would be not available (grayed out).
Video Input		
AV1, AV2	Auto ↔ HDTV ↔ SDTV/DVD	This should correspond to the signal mode of the signal from the equipment that is connected to AV1, 2 video input terminal. • Normally, set this to Auto. The signal mode of the input signal will be automatically recognized. • If the input signal contains much noise or has a low level at Auto and the operation is found erratic, set this to match the input signal.
RGB1	DVI-PC ↔ DVI-STB	This should correspond to the signal mode of the signal from the equipment that is connected to RGB1 DVI terminal.
RGB2 (1st step)	RGB ↔ Component	This should correspond to the signal mode of the signal from the equipment that is connected to RGB2 D-sub terminal.
RGB2 (2nd step)	Auto ↔ HDTV ↔ SDTV/DVD	This step should be set only when [Component] is selected on the 1st step. This should correspond to the signal mode of the signal from the equipment that is connected to RGB2 D-sub terminal. • Normally, set this to Auto. The signal mode of the input signal will be automatically recognized. • If the input signal contains much noise or has a low level at Auto and the operation is found erratic, set this to match the input signal.

OPERATING INSTRUCTIONS (continued)

SETUP MENU (RGB mode: RGB1 (DVI-PC), RGB2 (RGB))

ENGLISH

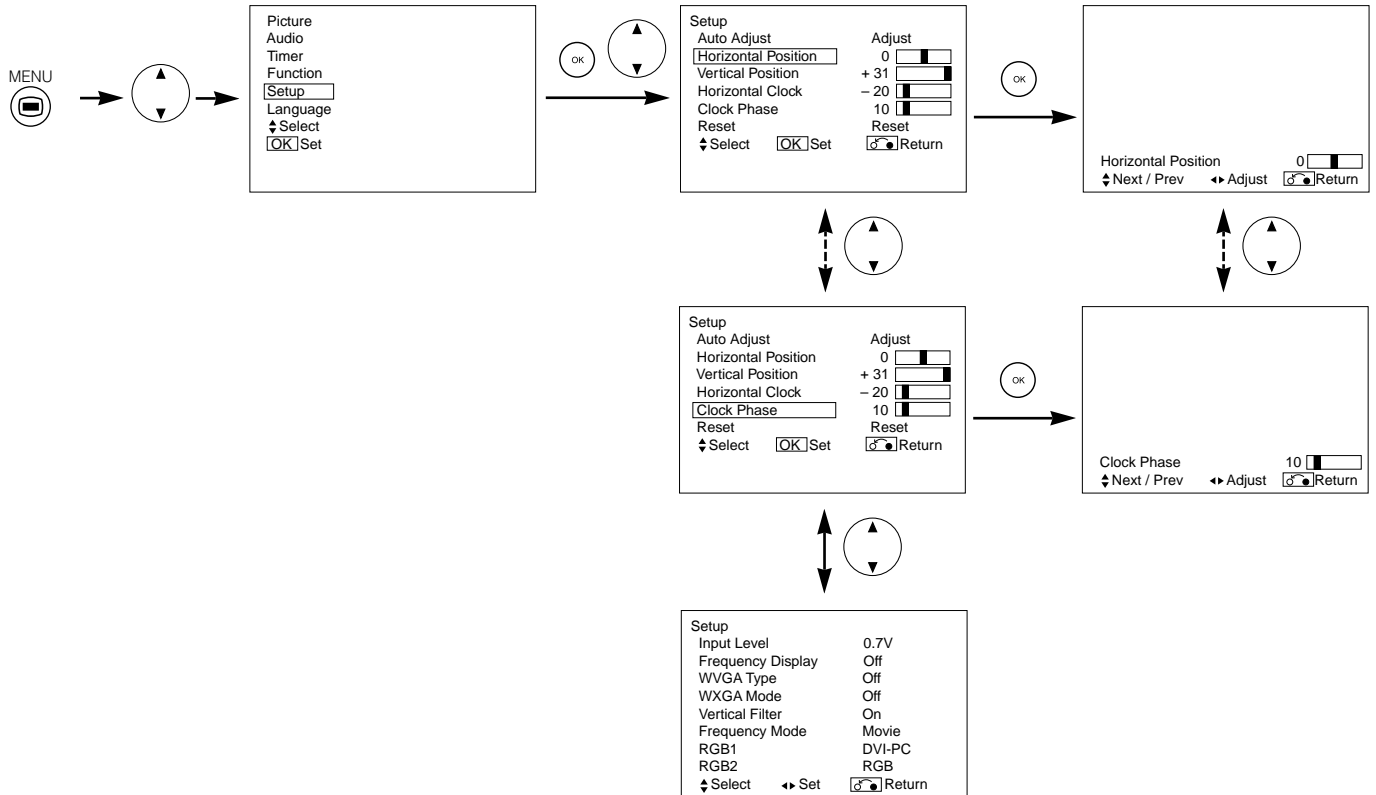

Selected characters	◀	▶	Setup hint
Auto Adjust*	-	Adjust Pressing the OK button here, Automatic regulation is started.	Horizontal Position, Vertical Position, Horizontal Clock and Clock Phase are adjusted automatically.
Horizontal Position	Moves the horizontal position to left. 	Moves the horizontal position to right. 	Adjust the left-side display position. Screen display changes to Magenta color if beyond the available range. (This function is only for RGB2. It's not available (grayed out) for RGB1 (DVI-PC).)
Vertical Position	Moves down the vertical position. 	Moves up the vertical position. 	Adjust the vertical display position. Screen display changes to Magenta color if beyond the available range. (This function is only for RGB2. It's not available (grayed out) for RGB1 (DVI-PC).)
Horizontal Clock	Reduces the dot clock frequency (shrinks the right side). 	Increases the dot clock frequency (expands the right side). 	Adjust for maximum character clarity. (This function is only for RGB2. It's not available (grayed out) for RGB1 (DVI-PC).)
Clock Phase	Slows the dot clock phase (shifts slightly to left). 	Advances the dot clock phase (shifts slightly to right). 	Adjust for clear character visibility. (This function is only for RGB2. It's not available (grayed out) for RGB1 (DVI-PC).)
Reset	(off the function)	(waiting to reset)	The original factory settings for the items of this Menu page can be restored by pressing the OK button.
Input Level			Normally set to 0.7 V. If white is found to spread across the screen, set to 1.0 V. (This is effective only for RGB2.)
Frequency Display			Set this to Off if the frequency information of the Input Signal Screen Display is not required.
WVGA Type			This is only available for W-VGA signal. When it is set to On, the display area mode can be selected Full or Real. (With RGB1 INPUT, the screen remains the same. RGB2 (ANALOG) INPUT only)
WXGA Mode			This is only available for W-XGA signal. (RGB2 (ANALOG) INPUT only)

OPERATING INSTRUCTIONS (continued)

SETUP MENU (RGB mode: RGB1 (DVI-PC), RGB2 (RGB)) (Continued)

Selected characters	◀ ▶	Setup hint
Vertical Filter	→ Off ↔ On ←	Turn On when concerned about screen flicker.
Frequency Mode	→ Movie ↔ PC ←	Set to Movie when viewing moving images on a personal computer.
RGB1	→ DVI-PC ↔ DVI-STB ←	This should correspond to the signal mode of the signal from the equipment that is connected to RGB1 DVI terminal.
RGB2 (1st step)	→ RGB ↔ Component ←	This should correspond to the signal mode of the signal from the equipment that is connected to RGB2 D-sub terminal.
RGB2 (2nd step)	→ Auto ↔ HDTV ↔ SDTV/DVD ←	This step should be set only when [Component] is selected on the 1st step. This should correspond to the signal mode of the signal from the equipment that is connected to RGB2 D-sub terminal. <ul style="list-style-type: none"> • Normally, set this to Auto. The signal mode of the input signal will be automatically recognized. • If the input signal contains much noise or has a low level at Auto and the operation is found erratic, set this to match the input signal.

* Depending on the type of signal displayed, displays may not be optimized through automatic adjustment. Adjust manually to optimize them.

OPERATING INSTRUCTIONS (continued)

FUNCTION MENU

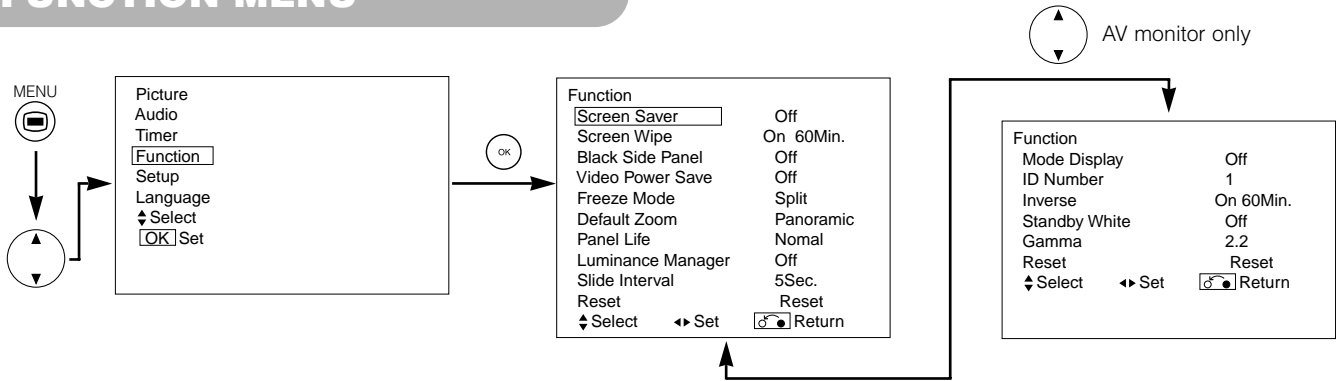

ENGLISH

Selected characters	◀	▶	Setup hint
Screen Saver	Off	5Min. 10Min. 60Min. 40Min. 20Min.	This moves the picture around the screen in small amounts, at set intervals, to reduce the panel image retention. This is where stationary objects, such as screen logos, leave a slight image visible after they should have disappeared.
Screen Wipe	On	60Min.	This is used to reduce the panel image retention that can occur with stationary pictures by the white field signal. Select On (continuous operation) or 60 Min. (time limit operation) and press the OK button. Press the MENU or RETURN button on the remote control to return to normal viewing.
Black Side Panel	Off	On	This turns the gray sidebars to the black sidebars when watching normal mode screen size area. It is always set to Off when the monitor powered On. It is recommended to set to Off to reduce the panel image retention. This is not available for the photo input function.
Video Power Save	Off	On	This is used to reduce power consumption for video input when there is no video signal. Setting it On will lead the monitor to the standby mode when the AV input with no signal is selected.
Freeze Mode	Split	Strobe	This selects the display condition of the FREEZE mode between Split (2 pictures) and Strobe (12 pictures). This is grayed out and not available in the AV monitor.
Default Zoom	Panoramic	4:3	This selects the screen display size of TV input that appears first when the main power turned on. This is grayed out and not available in the AV monitor.
Panel Life	Normal	Extend 1 Extend 2	This function is to suppress the contrast of the screen regardless of the Contrast setting in the Picture Menu. By this control, power consumption can be reduced or degradation of a panel can be mitigated. The order of power consumption is Extend 2 < Extend 1 < Normal. If the Contrast setting is changed when this item is set to Extend 1 or 2, it will be changed to Normal automatically.
Luminance Manager	Off	On	This is used to reduce the panel image retention which is caused by especially displaying TV station logo. Brightness of 4 corners of the panel get lower than the center.
Slide Interval	5Sec.	10Sec. 30Sec.	This is used to display images at set intervals during slide show. (37/42 only)
Reset	(off the function)	(waiting to reset)	The original factory settings for the items of this Menu page can be restored by pressing the OK button.
Mode Display	Off	On	This can display the Input Signal Screen Display every time the input mode and signal mode are changed. Set to OFF if the Input Signal Screen Display is not needed when switching signals.
ID Number	1	2 3 4 7 6 5	Assigns ID numbers to the monitors so that they can be controlled individually (up to 7 monitors can be controlled).
Inverse	On	60Min.	This function can change each level if RGB signal invert to reduce the panel image retention. When this function is required to use, select On (continuous operation) or 60Min. (time limit operation) and press OK button. And press the Menu or return button to exit.
Standby White	Off	15Min. 30Min. 120Min. 60Min.	This function is also provided against the image retention. If time is set for this item, the screen changes into the white pattern when the monitor enters power save mode, and it will continue for the period of setting time.
Gamma	2.2	2.8	Normally set to 2.2.

OPERATING INSTRUCTIONS (continued)

PICTURE MENU (TV/Video mode)

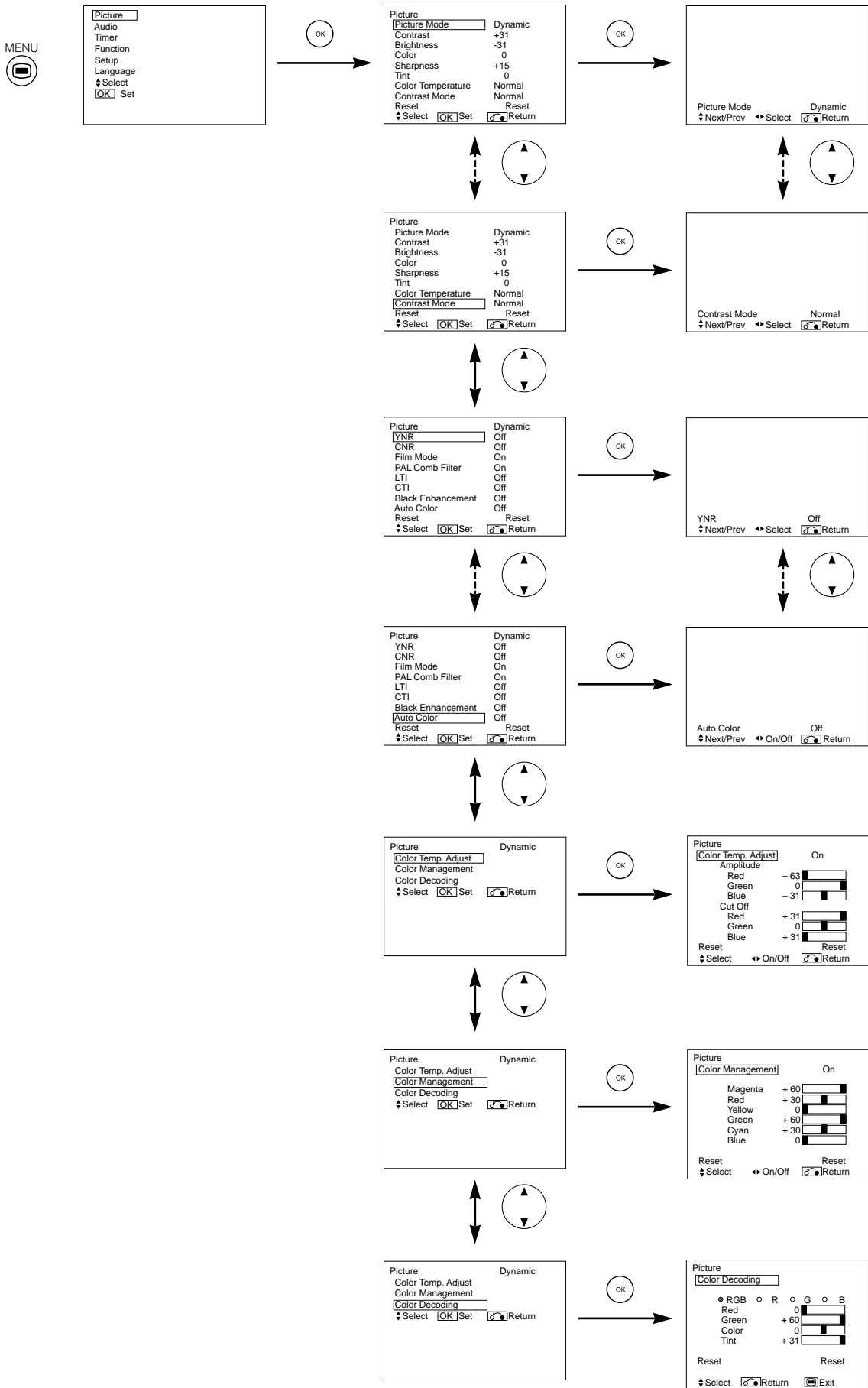

OPERATING INSTRUCTIONS (continued)

PICTURE MENU (TV/Video mode) (continued)

ENGLISH

Selected characters		◀	▶	Setup hint
Picture Mode				Dynamic: This setting is best for very bright ambient lighting. Natural: This setting is for normal lighting conditions. Cinema: This setting is best for watching movie.
Contrast		Narrows the gap between brightness and darkness.	Broadens the gap between brightness and darkness.	Adjust for maximum visibility to suit the ambient brightness. This can adjust further till [+40] by pressing and holding ► SELECT button at [+31]. The color for [+32] to [+40] numbers will change from white to magenta. This special mode is better for dark scenes. For normal viewing we recommend that the Contrast is set to [+31]. "Panel Life" in the Function Menu should be set to Normal when this Contrast setting is adjusted.
Brightness		Black is subdued for increased overall darkness.	Black is set off for increased overall brightness.	Adjust to preference.
Color		Decrease color intensity.	Increase color intensity.	Adjust to preference.
Sharpness		Soft	Sharp	Normally set to Centre position Shift to the minus (-) side for a softer effect and plus (+) for sharper picture.
Tint		Enhances red and weakens green.	Enhances green and weakens red.	This is not available to adjust when receiving PAL/SECAM signal. Then the character will be grayed out. Adjust for most realistic skin color.
Color Temperature				Normally set to Cool.
Contrast Mode				Dynamic: Emphasizes the differences between video shadings to improve the feeling of contrast. Normal: The gradation of an image is reproduced as faithfully as possible. Auto: Detects image brightness and automatically adjusts for natural brightness.
Reset		(off the function)	(waiting to reset)	The original factory settings for the items of this Menu page can be restored by pressing the OK button.
YNR				Performs picture signal noise reduction. Turn up to reduce noise.
CNR				Performs color signal noise reduction. Turn up to reduce noise. And it will be fixed as Off only when selecting DVI-STB mode.
Film Mode				On: Automatically detects the movie film material and faithfully reproduces the original film image. Off: Set to OFF when switching between images does not appear natural.
PAL Comb Filter				This is available only when receiving a PAL composite signal. Turn On to reduce the discolorations in fine picture detail and provides purer color.
LTI				Adjusts the sharpness of the picture signal.
CTI				Adjusts the sharpness of the color signal.
Black Enhancement				Adjusts the black level compensation.
Auto Color				This is available only when receiving an NTSC composite/S.Video signal. This monitors and adjusts the color to maintain constant color levels. It also maintains natural flesh tones while preserving fidelity of background colors.
Color Temp. Adjustment				Turn On when you wish to change color temperature depending on the user's preference.
Amplitude	Red	Brighter scene is decreased in reddish color.	Brighter scene is increased in reddish color.	Adjust color temperature depending on the user's preference. These settings are independently stored in each of the 4 Color Temperature modes.
	Green	Brighter scene is decreased in greenish color.	Brighter scene is increased in greenish color.	
	Blue	Brighter scene is decreased in bluish color.	Brighter scene is increased in bluish color.	
Cut Off	Red	Dark scene is decreased in reddish color.	Dark scene is increased in reddish color.	
	Green	Dark scene is decreased in greenish color.	Dark scene is increased in greenish color.	
	Blue	Dark scene is decreased in bluish color.	Dark scene is increased in bluish color.	

OPERATING INSTRUCTIONS (continued)

PICTURE MENU (TV/Video mode) (continued)

Selected characters	◀	▶	Setup hint
Color Management			Turn On when the original balance of each color is required to adjust depending on the user's preference.
Magenta	Magenta is weakened.	Magenta is strengthened.	This adjusts listed colors individually to make them either deeper or more pure. These settings are independently stored in each of the 4 Color Temperature modes.
Red	Red is weakened.	Red is strengthened.	
Yellow	Yellow is weakened.	Yellow is strengthened.	
Green	Green is weakened.	Green is strengthened.	
Cyan	Cyan is weakened.	Cyan is strengthened.	
Blue	Blue is weakened.	Blue is strengthened.	
Color Decoding			Select the single color screen when that is required to adjust R/G/B level individually depending on the user's preference. And set it back to RGB mode that indicates all color after adjusting. Press the OK button every time the setting is changed.
Red	Darkens red only.	Lightens red only.	This adjusts R/G/B level or tint to make the color appear natural for the user's preference. These settings are independently stored in each of the 4 Color Temperature modes. This does not work for receiving PAL/SECAM signal. Guide display become unavailable to select with gray color.
Green	Darkens green only.	Lightens green only.	
Color	Decrease color intensity.	Increase color intensity.	
Tint	Enhances red and weakens green.	Enhances green and weakens red.	

OPERATING INSTRUCTIONS (continued)

AUDIO MENU

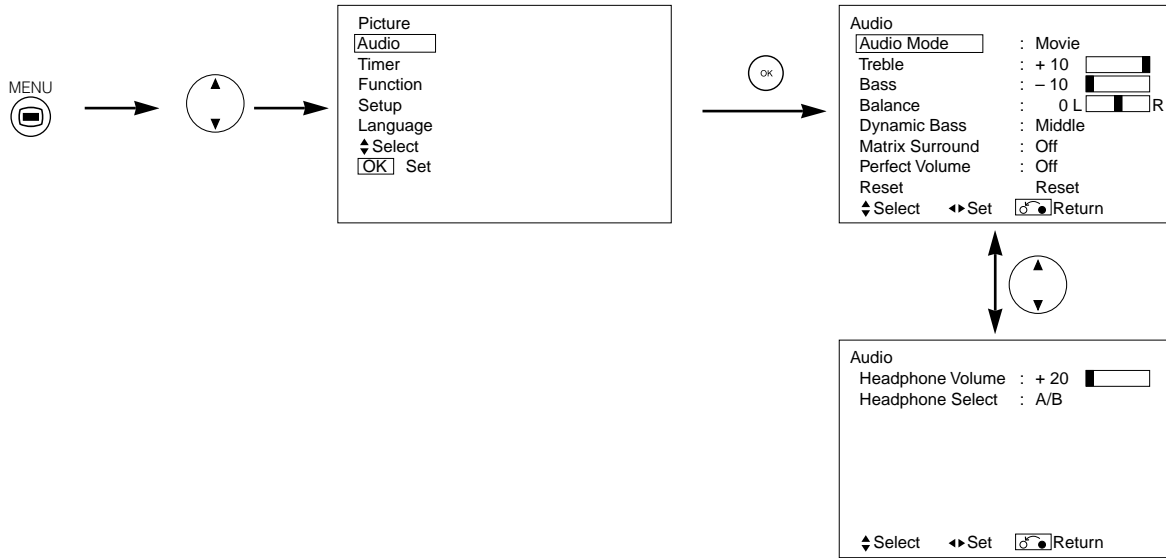

Selected characters	◀	▶	Setup hint
Audio Mode			Movie: This selects the audio suitable for Movie. Music: This selects the audio suitable for Music. Speech: This selects the audio suitable for News, Talk show etc. Favorite: This mode should be adjusted depending on user's preference.
Treble	Suppresses treble.	Enhances treble.	Adjust to preference.
Bass	Suppresses bass.	Enhances bass.	Adjust to preference.
Balance	Suppresses right-side sound.	Suppresses left-side sound.	Adjust to preference.
Dynamic Bass			Dynamic Bass takes advantage of the ability of the human ear to be able to distinguish between two different tones. By using this ability, Dynamic Bass gives enhanced bass sound that otherwise would not be heard. Adjust it depending on the user's preference.
Matrix Surround			This features the spacious sound effects of a stadium.
Perfect Volume			This will automatically adjust volume so each channel and input has the same average volume level.
Reset	(off the function)	(waiting to reset)	The original factory settings for the items of this Menu page can be restored by pressing the OK button.
Headphone Volume	Turns down the volume.	Turns up the volume.	This is to set the volume for headphone. The audio from the speaker is mute when connected to headphone terminal.
Headphone Select			A/B: During the 2 picture mode, the audio will be output from headphone on A (left picture) or B (right picture) to be selected. The speaker icon is located on the selected picture. B: The audio of B (right picture) is from headphone.

OPERATING INSTRUCTIONS (continued)

TIMER MENU

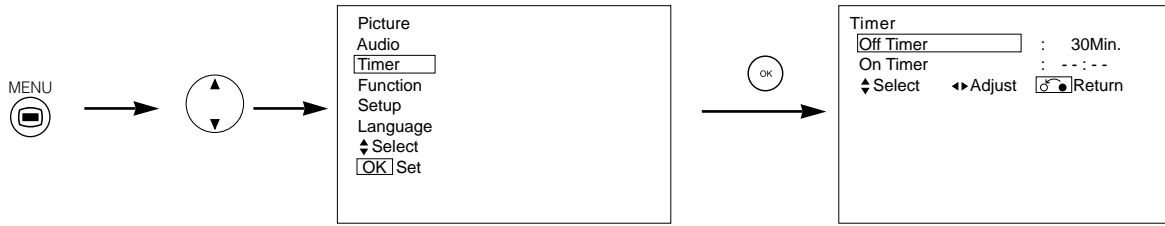

Selected characters	◀	▶	Setup hint
Off Timer	--Min. ↔ 30Min. ↔ 60Min. ↙ 120Min. ↔ 90Min. ↘		This function automatically sets the power to standby status when the indicated time period has elapsed.
On Timer	-- (:--) hours	(-- :)-- minutes	This automatically sets the power from standby to ON when the indicated time period has elapsed. The settable time is 00:00~11:59. Input the required time by ▲ and ▼ SELECT buttons on the remote control.

LANGUAGE MENU

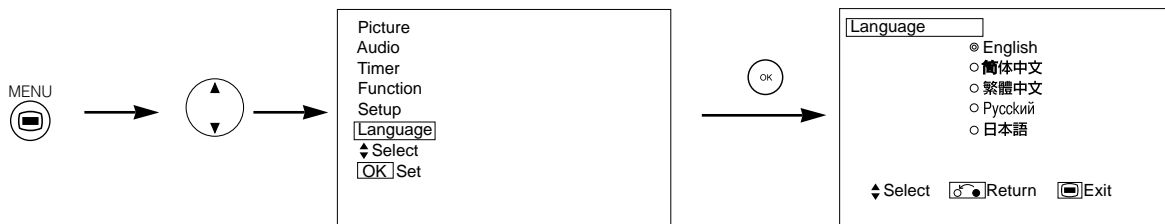

Select a language by ▲ and ▼ SELECT buttons and press the OK button.

OTHER FUNCTIONS

Automatic Store

Approximately 1 sec. after adjustment is completed, the adjustments will be recorded as shown in the table below.

Menu	Display	Registration condition
Picture	Picture Mode	1 setting is registered.
	Contrast	For every input function and every Picture Mode, 1 setting is registered.
	Brightness	
	Color	
	Sharpness	
	Tint	
	Color Temperature	
	Contrast Mode	
	YNR	
	CNR	
	Film Mode	
	PAL Comb Filter	
	LTI	
	CTI	
	Black Enhancement	
	Auto Color	
	Color Temp. Adjust	
	R Amplitude	For every Color Temperature, 1 setting is registered.
	G Amplitude	
	B Amplitude	
	R Cut Off	
	G Cut Off	
	B Cut Off	
	Color Management	For every input function and every Picture Mode, 1 setting is registered.
	Magenta	1 setting is registered.
	Red	
	Yellow	
	Green	
	Cyan	
	Blue	
	Color Decoding	-
	Red	For every Color Temperature, 1 setting is registered.
Green		
Color	For every input function and every Picture Mode, 1 setting is registered.	
Tint		
Audio	Audio Mode	1 setting is registered.
	Treble	For every Audio Mode, 1 setting is registered.
	Bass	
	Balance	1 setting is registered.
	Dynamic Bass	For every Audio Mode, 1 setting is registered.
	Matrix Surround	
	Perfect Volume	
	Headphone Volume	
Headphone Select		

Menu	Display	Registration condition
Function	Screen Saver	1 setting is registered.
	Screen Wipe	(not registered)
	Black Side Panel	1 setting is registered.
	Video Power Save	1 setting is registered.
	Freeze Mode	
	Default Zoom	
	Panel Life	
	Luminance Manager	
	Slide Interval	
	Mode Display	
	ID Number	
	Inverse	
	Standby White	
	Gamma	
Setup	System	1 setting is registered.
	Color System	-
	AV1	For every input function, 1 setting is registered.
	AV2	
	AV3	
	AV4	
	AV5	
	Video Input	-
	AV1	1 setting is registered.
	AV2	
	RGB1	(not registered)
	RGB2	
	Auto Adjust	
	Horizontal Position	For every signal Mode, 1 setting is registered. (Only for RGB2)
	Vertical Position	
	Horizontal Clock	
	Clock Phase	
	Input Level	1 setting is registered.
	Frequency Display	
WVGA Type		
WXGA Mode		
Vertical Filter		
Frequency Mode		
Language	1 setting is registered.	

- The previously recorded items will be lost.
- The signal mode can be identified by the horizontal/vertical sync frequency and the sync signal polarity. Different signals with which all the elements are the same or similar will be handled as the same signal.

OTHER FUNCTIONS (continued)

Audio Switching

A2 / NICAM / Sound Multiplex (TV mode)

- The CH I / II button is only useful for NICAM and sound multiplex signals. Otherwise pressing this button will have no effect.

BILINGUAL / DUAL sound broadcast

When bilingual program is received, sound mode display appears in yellow as shown on right.

Press the CH I / II button to select the sound to be heard.

Each time the button is pressed, I, II or ▼ (force mono) appear cyclically on the screen. When receiving NICAM signals, NICAM display will appear as below.

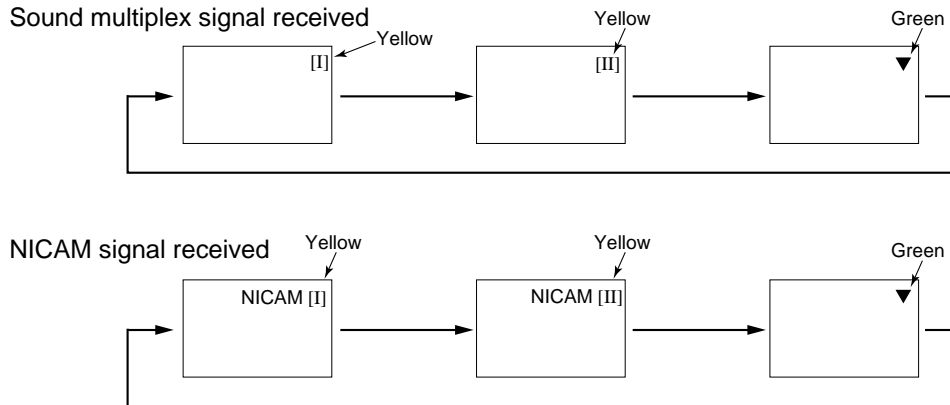
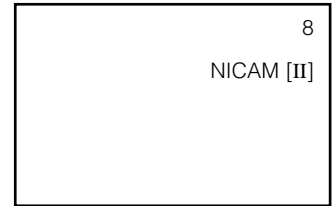

Select I, II or ▼ (force mono) to hear the CH I, CH II or MONO broadcast respectively.

STEREO sound broadcast

When a stereo program is received, sound mode display will appear in red, and you can press the CH I / II button to select between stereo and mono sound.

Each time the button is pressed, ○○ or ▼ (force mono) appear cyclically on the screen. When receiving NICAM signals, NICAM display will appear as below.

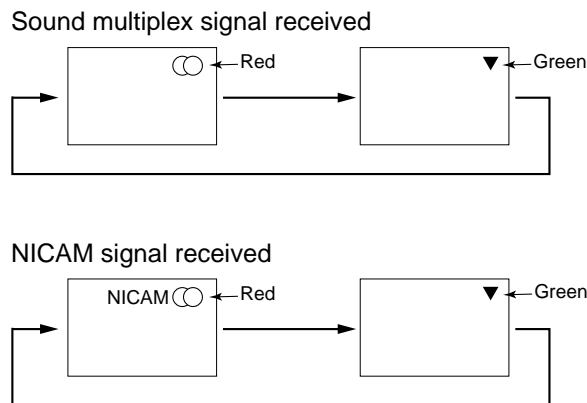

Select ○○ or ▼ (force mono) to hear the STEREO or MONO broadcast respectively.

Monaural sound broadcast

When a monaural program is received, sound mode display will appear in green.

You can press the CH I / II button to select the sound mode between monaural and forced mono (sound is same).

Each time the button is pressed, ▽ or ▼ (force mono) appear cyclically on the screen.



NOTE

- If sound signal is not strong enough for quality reception, press the CH I / II button until ▼ appears on the screen to receive a clear mono sound.
- If sound has hiss noise or keep switching between stereo and mono mode due to signal condition, press the CH I / II button until ▼ appears on the screen to receive a clear mono sound.

OTHER FUNCTIONS (continued)

Power Save Mode

When the RGB1, RGB2 input is selected

- When this unit is connected to a VESA DPMS computer, the Power Save (Off) mode can be set to be activated automatically when the computer is not being used to reduce power consumption by this unit.

RGB sync signal	Horizontal	Yes	No	Yes	No
	Vertical	Yes	Yes	No	No
PC signal		Active (normal display)		Blank (no display)	
Operation mode		On		Off	
Indicating lamp		Lights green		Lights orange	
Power consumption		245W (32) 320W (37) 380W (42)		3W or less (RGB1) 1W or less (RGB2 ; 100V≤AC≤120V) 3W or less (RGB2 ; 120V<AC<240V)	

Returning to operating status

- Operate the personal computer, or press either the INPUT SELECT button of the main unit or the RGB1/RGB2 buttons of the remote control.

DVD Player/STB Selection

- You can use this remote control to operate the selected maker of DVD player by pressing the following buttons on the remote control simultaneously.

<“DVD” Selection>

Makers of DVD player	Set Maker	Set Type	Makers of DVD player	Set Maker	Set Type
HITACHI	①	① ~ ③	RCA	①	①
FUNAI	②	①	Mitsubishi		①
Pioneer	③	① ~ ⑥	ONKYO	RED	① ~ ③
Panasonic	④	① ~ ④	ZENITH	GREEN	①
TOSHIBA	⑤	① ~ ④	THOMSON	YELLOW	①
Philips	⑥	① ~ ②	SHINCO	BLUE	①
JVC	⑦	①	SKYWORTH		①
SAMSUNG	⑧	①	BUBUKO		①
Sony	⑨	① ~ ④	DENON		① ~ ②
Sharp		① ~ ②			

<“SAT” Selection>

Makers of STB player	Set Maker	Set Type
HITACHI	①	① ~ ②
TOSHIBA	②	①
DGTECH	③	①
Panasonic	④	①

OTHER FUNCTIONS (continued)

DVD Player/STB Selection (continued)

Set up hint

Example) HITACHI DVD ①

To operate HITACHI DVD player, press and hold the **[i+]** button, followed by the **[1]** button.

1. Press **[SEL]** button to indicate the lamp of DVD on the remote control.

During LED lighting, press **[i+]** and **[1]** to set up the maker.

2. Release the **[1]** button once while keeping **[i+]** button, press the **[1]** button again to set the maker type.



* After set up the maker type, press the button related with DVD, and make sure that DVD player is working. In case DVD player does not work, repeat 1 and 2 with other numbers for the maker type to make sure it. (In this example, press **[2]** or **[3]**.)

NOTE

- Not all models of the listed makers can be operated using this remote control.

Signal Check (RGB mode)

Changes in the signal status are displayed on the screen as they arise.

Status	Display	Action
When Mode Display is set to ON, the input signal is switched or when the RECALL button is pressed.	A guide is displayed for the input terminal and the horizontal and vertical sync frequency.	_____
When the sync signal is no longer detected.	<ul style="list-style-type: none"> • A guide displays No Sync. Signal, and Power Save (for approx. 5 sec.) • When the condition continues where the sync signal cannot be detected, indicator lamp of power source changes in orange and the mode switches to power save mode. 	Recheck the personal computer power switch status and the connection status.
When the input signal does not match the monitor specifications or is in an unstable status.	A guide displays Invalid Scan Freq.	Recheck the input signal specifications.  54 ~ 57 

RGB

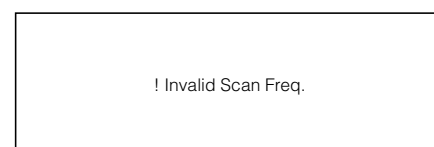
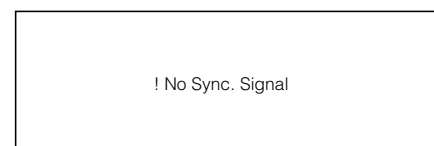
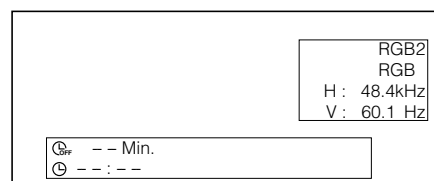









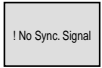

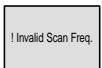
TROUBLESHOOTING

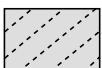
Symptoms That Seemingly Appear to be Failures

Make the checks suggested below depending on the symptoms observed. If the symptoms remain uncorrected, contact your dealer.

WARNING
 Customer servicing can be hazardous.

Symptom		Point to check	See page
<ul style="list-style-type: none"> No picture with the power-indicating lamp off. 		<ul style="list-style-type: none"> Check the way the power cable is connected. Press the power switch. 	<div style="border: 1px solid black; padding: 2px; width: 20px; margin: 2px auto;">20</div> <div style="border: 1px solid black; padding: 2px; width: 20px; margin: 2px auto;">21</div>
<ul style="list-style-type: none"> The message "No Sync. Signal" or "Power Save" is displayed. No picture with the power indicating lamp lights in orange. 	 	No sync signal is detected. <ul style="list-style-type: none"> Check the way the signal cable is connected. Make sure that the switch of the computer, imaging equipment, etc., is turned on. Make sure the computer is not in the power-save mode. Check to see if the input selection matches the connection terminal. 	<div style="border: 1px solid black; padding: 2px; width: 20px; margin: 2px auto;">16</div>
<ul style="list-style-type: none"> The message "Invalid Scan Freq." is displayed. 		An input signal is not received normally. <ul style="list-style-type: none"> Check to see if the input signal matches the monitor specifications. Check the way the signal cable is connected. 	<div style="border: 1px solid black; padding: 2px; width: 20px; margin: 2px auto;">16</div> <div style="border: 1px solid black; padding: 2px; width: 20px; margin: 2px auto;">55</div> <div style="border: 1px solid black; padding: 2px; width: 20px; margin: 2px auto;">56</div> <div style="border: 1px solid black; padding: 2px; width: 20px; margin: 2px auto;">57</div>
<ul style="list-style-type: none"> The power indicating lamp is normally lit but no picture. 		<ul style="list-style-type: none"> Check the contrast and brightness settings (adjust them for higher contrast and brightness). Check the way the signal cable is connected. 	<div style="border: 1px solid black; padding: 2px; width: 20px; margin: 2px auto;">16</div> <div style="border: 1px solid black; padding: 2px; width: 20px; margin: 2px auto;">41</div> <div style="border: 1px solid black; padding: 2px; width: 20px; margin: 2px auto;">43</div>
<ul style="list-style-type: none"> The display image appears flowing slant-wise. Text displayed across the screen appears vertically streaked, with the characters in vertical columns blurred. 	 	<ul style="list-style-type: none"> Adjust the dot clock frequency and phase. (Adjust the dot clock frequency first, the dot clock phase next.) (RGB input) 	<div style="border: 1px solid black; padding: 2px; width: 20px; margin: 2px auto;">37</div> <div style="border: 1px solid black; padding: 2px; width: 20px; margin: 2px auto;">52</div>
<ul style="list-style-type: none"> Text displayed across the screen appears blurred. A fine pattern flickers when displayed on the screen. 	 	<ul style="list-style-type: none"> Adjust the dot clock phase for the clearest viewing. (RGB input) 	<div style="border: 1px solid black; padding: 2px; width: 20px; margin: 2px auto;">37</div> <div style="border: 1px solid black; padding: 2px; width: 20px; margin: 2px auto;">52</div>
<ul style="list-style-type: none"> The remote control does not work. 		<ul style="list-style-type: none"> Check to see if the batteries are loaded in the remote control in opposite direction. Check to see if the batteries in the remote control are OK. 	<div style="border: 1px solid black; padding: 2px; width: 20px; margin: 2px auto;">10</div>
<ul style="list-style-type: none"> The display image does not appear in the normal position. 		<ul style="list-style-type: none"> Check to see if the displayed input signal match the monitor specification by pressing (i+) button. Turn off the screen saver. 	<div style="border: 1px solid black; padding: 2px; width: 20px; margin: 2px auto;">16</div> <div style="border: 1px solid black; padding: 2px; width: 20px; margin: 2px auto;">39</div> <div style="border: 1px solid black; padding: 2px; width: 20px; margin: 2px auto;">55</div> <div style="border: 1px solid black; padding: 2px; width: 20px; margin: 2px auto;">56</div> <div style="border: 1px solid black; padding: 2px; width: 20px; margin: 2px auto;">57</div>
<ul style="list-style-type: none"> The display has picture missing on the screen. (PC input mode only) 		<ul style="list-style-type: none"> Turn off the screen saver. 	<div style="border: 1px solid black; padding: 2px; width: 20px; margin: 2px auto;">39</div>
<ul style="list-style-type: none"> The temperature of the display panel surface is high. 		<ul style="list-style-type: none"> The plasma display panel is lighting the phosphors by the discharge of internal radiation. In some cases, this may cause the temperature of the panel surface to increase. Please note that this is not a malfunction. 	-

TROUBLESHOOTING (continued)

Symptoms That Seemingly Appear to be Failures (continued)

Symptom	Point to check	See page
<ul style="list-style-type: none"> There are locations on the screen that are different from the periphery (*). *Points that do not light, points with brightness different from that of the periphery, points with color different from that of the periphery, etc. 	<ul style="list-style-type: none"> High-precision technology is used to manufacture the plasma display panel, However in some cases, there are minor defects in some parts of the screen. Please note that this is not a malfunction. 	-
<ul style="list-style-type: none"> Vertical stripes appear, depending on the screen contents. 	<ul style="list-style-type: none"> The plasma display panel is lighting the phosphors by the discharge of internal radiation. Depending on the screen contents, in rare cases this may cause vertical stripes to appear because of failure to light. Please note that this is not a malfunction. 	-
<ul style="list-style-type: none"> Coarse horizontal stripes appear in FULL display. 	<ul style="list-style-type: none"> Adjusting the Clock Phase will reduce the horizontal stripes. (RGB input) 	37
<ul style="list-style-type: none"> Flickering in the form of horizontal lines oscillating up and down. (PC INPUT MODE only) 	<ul style="list-style-type: none"> If the direct frequency from the computer is below 85Hz, try a higher frequency (upper limit 85Hz). There may be a slight attenuation of the current image. Try turning the Vertical Filter On. For this case however, the vertical resolution will drop. 	38
<ul style="list-style-type: none"> The top of the monitor heats up. 	<ul style="list-style-type: none"> When used for long periods of time, the top of the monitor may heat up. This is not a malfunction. 	-
<ul style="list-style-type: none"> Text characters are displayed with varying thicknesses. 	<ul style="list-style-type: none"> The thicknesses of characters and lines may vary if images with a vertical resolution greater than 512 lines are displayed; however, this is not a malfunction. 	-
<ul style="list-style-type: none"> The screen becomes dark and the images cannot be seen during VTR special playback (fast forward, rewind) 	<ul style="list-style-type: none"> This sometimes occurs when a component output VTR such as the 480i is connected. This is not a malfunction; therefore, please take note that this may occur. When it does occur, change to composite output, or S.video output. 	-
<ul style="list-style-type: none"> During multi picture mode, sub pictures are not displayed. 	<ul style="list-style-type: none"> Sub pictures image might not be able to be displayed, depending on the combination. (Refer to the table of "2 picture mode" and "4 picture mode") 	28
<ul style="list-style-type: none"> The screen display sizes are not switched. 	<ul style="list-style-type: none"> The screen display size is fixed at "Full" as receiving 1080i/60Hz, 1080i/50Hz, and 720p. 	-
<ul style="list-style-type: none"> Images from AV6 (HDMI) are not displayed. 	<ul style="list-style-type: none"> Check the cable and output format of connecting device. (Refer to "Connecting to an Audio Visual Device") 	14
<ul style="list-style-type: none"> Images from Photo Input are not displayed. 	<ul style="list-style-type: none"> Check the connecting device and image format. (Refer to "Photo Input Display") 	30 31 32

TROUBLESHOOTING (continued)

Actions to Correct Abnormal Displays

Depending on the kind of system equipment used, images may not be displayed normally. In this case, make the adjustments suggested below. (only for RGB2)





Symptom 1	Text displayed across the screen appears vertically streaked, with some characters blurred (Figure 1). (RGB input).	
Example	<p>Figure 1</p> <p>Vertical streaks</p> <p>Before adjustment, some characters are blurred.</p> <p>After adjustment, all characters appear crisp now.</p> <p>After adjustment, all characters are blurred.</p>	
Adjustment procedure	<ol style="list-style-type: none"> 1) Press the MENU button. The Main Menu will be displayed. 2) Press the ▼ SELECT button and select Setup. 3) Press the OK button. The Setup Menu will be displayed. 4) Press the ▼ SELECT button and select Auto Adjust. <p>When adjustment is not possible with Auto Adjust</p> <ol style="list-style-type: none"> 5) Press the MENU button. The Main Menu will be displayed. 6) Press the ▼ SELECT button and select Setup. 7) Press the OK button. The Setup Menu will be displayed. 8) Press the ▼ SELECT button and select Horizontal Clock. <p>(Display fine patterns as characters or a vertical striped pattern over the entire screen during Horizontal Clock adjustment.)</p> <ol style="list-style-type: none"> 9) Press the ► or ◀ ADJUST buttons and search for clear characters over the entire screen. 10) Perform adjustment for symptom 2 below, when the characters are blurred on the entire screen. 	

• The display image may be momentarily disturbed during clock adjustment but this is not a failure.

Symptom 2	Text displayed across the screen appears blurred in its entirety (Figure 2). A fine pattern flickers when displayed on the screen (Figure 3).	
Example	<p>Figure 2</p> <p>Before adjustment</p> <p>After adjustment</p>	<p>Figure 3</p> <p>Before adjustment</p> <p>After adjustment</p>
Adjustment procedure	<ol style="list-style-type: none"> 1) Press the MENU button. The Main Menu will be displayed. 2) Press the ▼ SELECT button and select Setup. 3) Press the OK button. The Setup Menu will be displayed. 4) Press the ▼ SELECT button and select Auto Adjust. <p>When adjustment is not possible with Auto Adjust</p> <ol style="list-style-type: none"> 5) Press the MENU button. The Main Menu will be displayed. 6) Press the ▼ SELECT button and select Setup. 7) Press the OK button. The Setup Menu will be displayed. 8) Press the ▼ SELECT button and select Clock Phase. <p>(Display fine patterns as characters or a vertical striped pattern over the entire screen during Clock Phase adjustment.)</p> <ol style="list-style-type: none"> 9) Press ► or ◀ ADJUST buttons to make the text appear clean across the screen. 	
		<ol style="list-style-type: none"> 9) Press ► or ◀ ADJUST buttons to make the text appear without flickering.

PRODUCT SPECIFICATIONS

This table shows the specifications when the optional video unit and tuner unit have been inserted.

Panel	Display dimensions	Approx. 32 inches (716 (H) x 399 (V) mm, diagonal 820mm)	Approx. 37 inches (814 (H) x 445 (V) mm, diagonal 930mm)	Approx. 42 inches (922 (H) x 522 (V) mm, diagonal 1059mm)
	Resolution	852 (H) x 1024 (V) pixels	1024 (H) x 1024 (V) pixels	1024(H) x 1024 (V) pixels
Net dimensions (excluding Speakers/Stand)		850 (W) x 545 (H) x 110 (D) mm	959 (W) x 612 (H) x 118 (D) mm	1050 (W) x 676 (H) x 110 (D) mm
Net weight (excluding Speakers/Stand)		25.5kg	30.5kg	37.0kg
Ambient conditions	Temperature	Operating : 5°C to 35°C, Storage : 0°C to 40°C		
	Relative humidity	Operating : 20% to 80%, Storage : 20% to 90% (non-condensing)		
Power supply		AC100 - 240V, 50/60Hz		
Power consumption/at standby		245W / <3W	320W / <3W	380W / <3W
Audio output		speaker 12W + 12W (6Ω)	speaker 12W + 12W (6Ω)	speaker 12W + 12W (6Ω),
(RGB input)				
Input terminals		RGB1 DVI input terminal (DVI-D) RGB1 audio input terminal (3.5mm Stereo Mini Jack) RGB2 analog RGB input terminal (D-sub 15-pin) RGB2 audio input terminal (3.5mm Stereo Mini Jack)		
Input signals		0.7 V/1.0 Vp-p, analog RGB (Recommended Signal) 480i, 576i, 480p, 576p, 1080i/50, 1080i/60, 720p/60		
Sync signals		H/V separate, TTL level [2KΩ] H/V composite, TTL level [2KΩ] Sync on green, 0.3 Vp-p [75Ω]		
Recommended signal		44 modes  		
(Video input)				
Input terminals		AV1: composite video input terminal (RCA) AV1: Y PB PR video input terminal (RCA) AV1: L/R audio input terminal (RCA) AV2: composite video input terminal (RCA) AV2: Y/ P _B / P _R / video input terminal (RCA) AV2: L/R audio input terminal (RCA) AV3: composite video input terminal (RCA) AV3: S video input terminal AV3: L/R audio input terminal (RCA) AV4: composite video / L/R audio input terminal (RCA) AV5=AV3 AV6=HDMI input terminal Photo input terminal (37/42 only)		
Input signals		AV1: PAL, SECAM, NTSC3.58, NTSC4.43 AV1: 480i, 576i, 480p, 576p, 1080i/50, 1080i/60, 720p/60 AV2: PAL, SECAM, NTSC4.43, NTSC3.58 AV2: 480i, 576i, 480p, 576p, 1080i/50, 1080i/60, 720p/60, RGB AV3: PAL, SECAM, NTSC4.43, NTSC3.58, AV4: PAL, SECAM, NTSC4.43, NTSC3.58, AV5=AV3 AV6=HDMI input signal 		
Output Signal		OUTPUT (MONITOR): composite video monitor-output terminal (RCA) OUTPUT (MONITOR): L/R audio monitor- output terminal (RCA) OUTPUT (HEADPHONE): L/R audio monitor- output terminal (Mini-pin)		
Recommended signal		23 modes 		
(RF input)				
Input terminals		ANT : 75Ω Unbalanced		
RF Video System		PAL B, G, H / I / D, K SECAM B, G / D, K / K1 NTSC-M		

- The monitor takes at least 30 minutes to attain the status of optimal picture quality.
- RF input : TV only

PRODUCT SPECIFICATIONS (continued)

Signal Input

RGB terminal (D-sub 15-pin connector)

Pin	Input signal
1	R (P _R /C _R)
2	G or sync on green (Y)
3	B (P _B /C _B)
4	No connection
5	No connection
6	R.GND (P _R /C _R , GND)
7	G.GND (Y, GND)
8	B.GND (P _B /C _B , GND)
9	No connection
10	GND
11	No connection
12	[SDA]
13	H. sync or H/V composite sync
14	V.sync. [V.CLK]
15	[SCL]

() : With component input

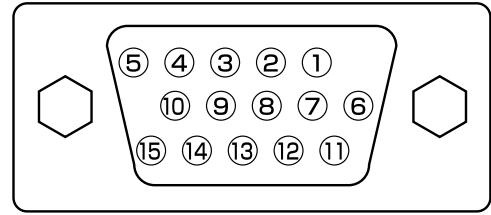

- When different kinds of input signals are simultaneously input to the monitor via a graphics board or the like, the monitor will automatically select the signals in the following priority order:

Sync signal type	Priority
H/V separate sync.	1
H/V composite sync.	2
sync.on Green *	3

* Even in the case of the recommended signals shown on the following page, there may be instances when correct display is not possible. In this case, use H/V separate sync, H/V composite sync.

S-input connector pin specifications

Pin	Input signal
1	Y
2	Y-GND
3	C
4	C-GND
Frame	GND

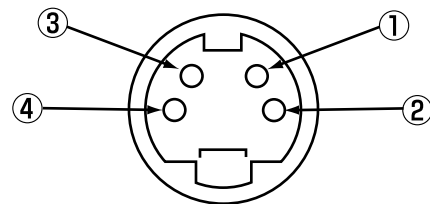
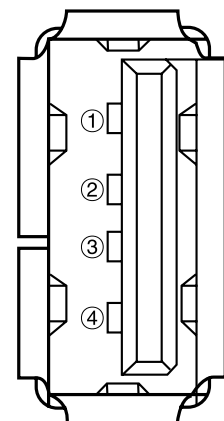

Photo-input connector pin specifications

Pin	Input signal
1	5V
2	DM
3	DP
4	GND



HDMI connector pin specifications



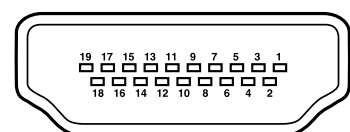



Pin	Input signal	Pin	Input signal
1	TMDS Data2+	11	TMDS Clock Shield
2	TMDS Data2 Shield	12	TMDS Clock-
3	TMDS Data2-	13	CEC
4	TMDS Data 1+	14	Reserved(N.C. on device)
5	TMDS Data1 Shield	15	SCL
6	TMDS Data1-	16	SDA
7	TMDS Data0+	17	DDC/CEC Ground
8	TMDS Data0 Shield	18	+5V Power
9	TMDS Data0-	19	Hot Plug Detect
10	TMDS Clock+		



PRODUCT SPECIFICATIONS (continued)

Recommended Signal List

Applicable video signals for input terminal (TV mode)

Terminal	RCA/S-video			HDMI	DVI		D-sub		Remarks
	Signal	CVBS	S-video		Component	PC	STB	RGB	
AV1	○			○					Refer to Setup Menu  36
AV2	○			○					Refer to Setup Menu  36
AV3	○	○							Refer to Setup Menu  36
AV4	○								Refer to Setup Menu  36
AV5	○	○							Refer to Setup Menu  36
AV6				○					
RGB1					○	○			Refer to Setup Menu  37
RGB2							○	○	Refer to Setup Menu  37

(○ : Available)

With Composite Input(AV1~AV5 input) and S-video Input (AV3, AV5 input).

No.	Signal mode			Horizontal frequency (kHz)	Dot clock frequency (MHz)	Remarks
	Signal Name	Resolution	Vertical frequency (Hz)			
1	NTSC4.43 NTSC3.58	525	59.94	15.73	—	
2	PAL SECAM	625	50.00	15.63	—	

With component input (AV1, AV2 and RGB2-component input).

No.	Signal mode			Horizontal frequency (kHz)	Dot clock frequency (MHz)	Remarks
	Signal Name	Resolution	Vertical frequency (Hz)			
1	576i	576	50.00	15.63	—	
2	480i	480	59.94	15.73	—	
3	576p	576	50.00	31.26	—	
4	480p	480	59.94	31.47	—	
5	1080i/50	1080	50.00	28.13	—	
6	1080i/60	1080	60.00	33.75	—	
7	720p/60	720	60.00	45.00	—	

With HDMI input (AV6 input).

No.	Signal mode			Horizontal frequency (kHz)	Dot clock frequency (MHz)	Remarks
	Signal Name	Resolution	Vertical frequency (Hz)			
1	VGA	640 x 480	59.94	31.47	25.18	EIA-861B
2	576i	720(1440) x 576	50.00	15.63	27.00	EIA-861B
3	480i	720(1440) x 480	59.94	15.73	27.00	EIA-861B
4	576p	720 x 576	50.00	31.25	27.00	EIA-861B
5	480p	720 x 480	59.94	31.47	27.00	EIA-861B
6	1080i/50	1920 x 1080	50.00	28.13	74.25	EIA-861B
7	1080i/60	1920 x 1080	60.00	33.75	74.25	EIA-861B
8	720p/60	1280 x 720	60.00	45.00	74.25	EIA-861B

PRODUCT SPECIFICATIONS (continued)

Recommended Signal List (continued)

With Digital signal input

No.	Signal mode			Horizontal frequency (kHz)	Dot clock frequency (MHz)	Setup Menu Condition		Remarks
	Signal Name	Resolution	Vertical frequency (Hz)			DVI-PC	DVI-STB	
1	VGA	640 X 400	70.08	31.47	25.18	○		
2		640 X 480	59.94	31.47	25.18	○	○	
3	W-VGA	864 X 480	59.94	31.47	34.24	○		WVGA type : On
4	VESA	640 X 480	72.81	37.86	31.50	○		
5		640 X 480	75.00	37.50	31.50	○		
6		640 X 480	85.01	43.27	36.00	○		
7		800 X 600	56.25	35.16	36.00	○		
8		800 X 600	60.32	37.88	40.00	○		
9		800 X 600	72.19	48.08	50.00	○		
10		800 X 600	75.00	46.88	49.50	○		
11		800 X 600	85.06	53.67	56.25	○		
12		1024 X 768	60.00	48.36	65.00	○		
13		1024 X 768	70.07	56.48	75.00	○		
14	1024 X 768	75.03	60.02	78.75	○			
15	480p	720 X 480	59.94	31.47	27.00		○	EIA-861B
16	576p	720 X 576	50.00	31.25	27.00		○	EIA-861B
17	720p/60	1280 X 720	60.00	45.00	74.25		○	EIA-861B
18	1080i/60	1920 X 1080	60.00	33.75	74.25		○	EIA-861B
19	1080i/50	1920 X 1080	50.00	28.13	74.25		○	EIA-861B

(○ : acceptable)

PRODUCT SPECIFICATIONS (continued)

Recommended Signal List (continued)

With Analog signal input (RGB2 input)

No.	Signal mode			Horizontal frequency (kHz)	Dot clock frequency (MHz)	Remarks
	Signal Name	Resolution	Vertical frequency (Hz)			
1	VGA	640 X 400	70.08	31.47	25.18	
2		640 X 480	59.94	31.47	25.18	
3	W-VGA	864 X 480	59.94	31.47	34.24	WVGA type : On
4	VESA	640 X 480	72.81	37.86	31.50	
5		640 X 480	75.00	37.50	31.50	
6		640 X 480	85.01	43.27	36.00	
7		800 X 600	56.25	35.16	36.00	
8		800 X 600	60.32	37.88	40.00	
9		800 X 600	72.19	48.08	50.00	
10		800 X 600	75.00	46.88	49.50	
11		800 X 600	85.06	53.67	56.25	
12		1024 X 768	60.00	48.36	65.00	
13		1024 X 768	70.07	56.48	75.00	
14		1024 X 768	75.03	60.02	78.75	
15		1024 X 768	85.00	68.68	94.50	
16		1152 X 864	75.00	67.50	108.00	
17		1280 X 1024	60.02	63.98	108.00	
18		1280 X 1024	75.03	79.98	135.00	
19		1280 X 1024	85.02	91.15	157.50	
20		1600 X 1200	60.00	75.00	162.00	
21		1600 X 1200	75.00	93.75	202.50	
22		1600 X 1200	85.00	106.25	229.50	
23		Macintosh	640 X 480	66.67	35.00	30.24
24	832 X 624		74.55	49.72	57.28	
25	1024 X 768		74.93	60.24	80.00	
26	1152 X 870		75.06	68.68	100.00	
27	W-XGA	1280 X 768	59.833	47.986	81.00	
28		1280 X 768	69.997	56.137	94.760	
29	W-XGA	1280 X 768	59.876	47.776	79.50	WXGA Mode : 1280x768
30		1366 X 768	60.015	47.712	85.50	WXGA Mode : 1366x768

- The type of video board or connecting cable used may not allow for correct displays adjustment of Horizontal Position, Vertical Position, Horizontal Clock and Clock Phase.
- The monitor may fail to display an animation image correctly when a signal having a vertical frequency of 85Hz or higher is input to it.
- The monitor differentiates the signal modes according to the horizontal and vertical frequencies and the horizontal and vertical sync signal polarities. Note that different signals having all these elements alike may be handled as the same signal.
- Displaying images with more than 512 lines of vertical resolution at Full display (compressed display) can result in the interpolation of stripes.