

CP-A302WNM

ULTIMATE 究極 SHORT THROW



ULTIMATE SHORT THROW XGA LCD PROJECTOR

The light weight and compact CP-A302WNM Ultimate Short Throw projector offers the highest quality images with a compelling design and low cost of ownership. With the bundled wall mount and optional table top kit you can project onto any existing whiteboard, wall or table top. Easy to install and flexible to use with optional wireless networking making the CP-A302WNM the ideal solution for any education or corporate environment.

Performance

- XGA resolution (1024 x 768)
- 80" (2m) image from only 50cm*
- 3000 ANSI Lumens (Normal Mode)
- Full connectivity including HDMI
- Perfect Fit – adjust all four corners and sides of the image individually to achieve a square image
- Input Source Naming
- My Button
- Table top mount facility
- 10W speaker
- Anti theft features including:
 - PIN-Lock
 - MyScreen Lock
 - Transition Detector
 - Security bar

Cost of ownership

- Extended Hybrid Filter life: 4000hr cleaning cycle
- Extended lamp life: 5000hrs (Eco Mode)
- Virtually maintenance free
- Easy set up and installation - New on screen installation guide
- Power Saving Mode (ImageCare™)
- Wall mount included in the box

Advanced Network Features

- Full connectivity including 1 x RJ-45
- Optional wireless networking†
- Configure and control projector via network with a web browser
- Projector management via SNMP
- Content via LAN
- AMX Device Discovery
- Messenger
- Cloning function
- PJ Link™
- Network Bridge
- iOS Connectivity

Environment

- The extended Hybrid Filter life means reduced electronic waste and reduced maintenance visits, resulting in an overall reduction in carbon footprint
- ImageCare™ - The combination of Eco and Saver Modes conserve energy

Hitachi have formulated an "Environmental Vision" to contribute towards building a sustainable society through business and product development.

Our goal is to develop life-enhancing technology that will contribute to and realise a truly sustainable society for current and future generations.

*From centre of mirror to screen.

†Wireless is optional on this model (USB wireless adapter sold separately).



www.hitachi.com.au/dps

HITACHI
Inspire the Next

CP-A302WNM

Technical Specifications

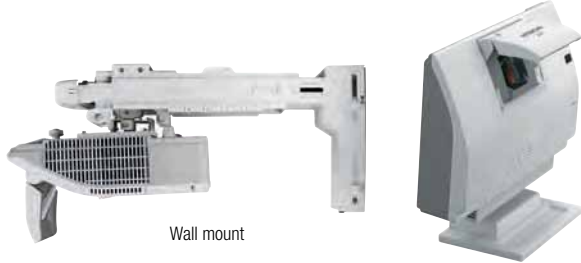
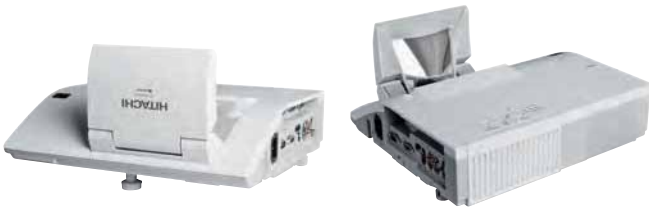

Wall mount

Table mount (optional)

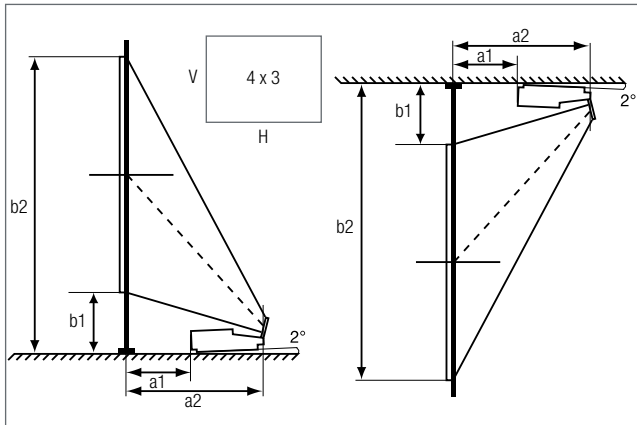
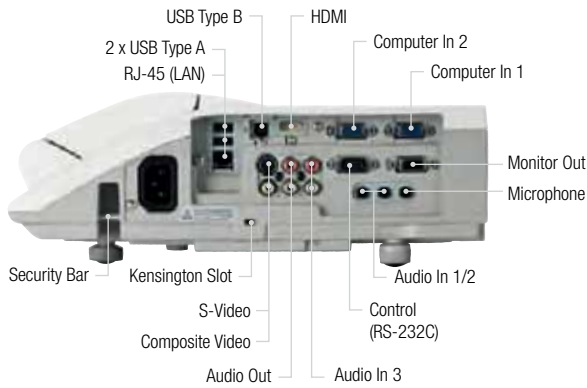

Throw distance (from the top of the lens)

Screen size (diagonal)	H x V		a1	a2	b1	b2
	(m)	(m)				
60" (1.5m)	1.2	0.9	0.096	0.373	0.281	1.196
70" (1.8m)	1.4	1.1	0.161	0.437	0.317	1.384
80" (2.0m)	1.6	1.2	0.225	0.501	0.352	1.571
90" (2.3m)	1.8	1.4	0.289	0.566	0.387	1.759
100" (2.5m)	2.0	1.5	0.353	0.630	0.423	1.947



OPTICAL

LCD panel	0.63" (1.6cm) P-Si TFT x3
Resolution	XGA (1024 x 768)
Light output (brightness)	3000 ANSI Lumens (Normal Mode)/2000 ANSI Lumens (Eco Mode)
Colour light output (colour brightness)	3000 ANSI Lumens (Normal Mode)/2000 ANSI Lumens (Eco Mode)
Contrast ratio	4000:1
Lens	Free shaped lens and motorised free shaped mirror
Lamp Wattage	215 W
Lamp life	3000 Hours (Normal Mode)/5000 Hours (Eco Mode)*
Focus distance	0.4m-0.7m (from mirror top to screen plane)
Distance to width ratio (:1)	0.3:1 (fixed)
Diagonal display size	60-100" (152-254cm)
Number of colours	8 Bit/colour, 16.7M colours
Keystone	Fixed, 6.1:-1 upward shift, Normal at +71.1° projection angle

COMPATIBILITY

Computer compatibility	IBM Compatible VGA, SVGA, XGA, WXGA, WXGA+, SXGA, SXGA+, UXGA (compressed), MAC 16"
Composite/S-Video	NTSC, PAL, SECAM, PAL-M, PAL-N, NTSC4.43
Component Video	525i(480p), 525p(480p), 625i(576i), 1125i(1080i@50/60), 1125p(1080p@50/60), 750p(720p@50/60)
HDMI	1125i(1080i@50/60), 750p(720p@50/60), 1125p(1080p@50/60)
Plug & Play	DDC2B

FEATURES

Speakers	16W x 1 Mono
Basic functions	Freeze, Magnifying, Blank, Auto adjustment, Mirror reverse image, Up-side down image, Auto signal search
Picture adjustments	Digital Zoom x 1.35, Equalising Digital Gamma Correction, 2-3 pull down for NTSC, Progressive Scan, Noise reduction, Aspect selection 4:3/16:9/16:10/14:9/Native - dependant on source, Equalising colour temperature adjustment, Perfect Fit Horizontal ±5°, Vertical ±5°
Digital keystone	
Advanced features	Drawing function (optional wireless tablet TB-1 required), My Screen, My Memory, My Button by remote control, My Source, My Text, Picture mode (8 modes), Source naming (English), Resolution setting, Template, Saving mode, Audio pass through, Cloning, Audio sound mixing, Audio out (standby) and monitor out/selectable source with menu, Eco Mode (Normal, Eco, Intelligent Eco, Saver), Filter timer/selectable interval time, PC-less Presentation (JPEG, PNG, BMP, GIF, AVI, MOV), Stand-by Audio, On screen installation guide, IOS Connectivity
Outward Power on & off	Easy Lamp replace from Top, Rear intake air filter
Security systems	Direct on, Auto off, Auto eco mode PIN Security Lock, Myscreen Password Lock, Transition Detector, My Text Password Lock, Key Lock (key pad, remote control), Kensington slot, Security bar, Lens door lock
Network	Configure and control projector via web browser, Failure and warning alerts via e-mail, Scheduling, My Image (still image transfer display), Displaying text data transferred via the network, Command Control via network, Crestron RoomView® (not accessible through wireless adapter), AMX Device Discovery, Projector management via SNMP, P.J Link™, Network Bridge, Network Presentation (PC still picture transfer), MAC address on side, USB Display
OSD languages options	33, including: English, French, German, Spanish, Italian, Norwegian, Dutch, Japanese, Portuguese, Swedish, Russian, Finnish, Polish, Turkey, Arabic, Czech, Danish, Hungarian, Romanian, Slovenian, Croatian, Greek, Lithuanian, Estonian, Latvian

CONNECTIONS

Digital input	1 x HDMI (HDCP compatible)
Computer input	2 x 15-pin Mini D-sub
Monitor output	1 x 15-pin Mini D-sub
Video input	1 x RCA Jack (for composite), 1 x S-Video Jack, 2 x Component D-sub (shared with analogue computer in 1/2)
Audio input	2 x Stereo Mini Jack, 1 x pair RCA (L/R), 1 x Microphone Jack
Audio output	1 x pair RCA (L/R)
Control	1 x 9-pin D-sub for RS232 control
USB	2 x USB type A, 1 x USB type B
Wired network	1 x RJ-45
Wireless network	Option, IEEE801.11b/g/n ready (optional wireless adapter required)

POWER

Power supply	AC100-120V/220-240V, auto switching
Power consumption/standby	310W (AC220-240V)/<0.35W

PHYSICAL

Dimensions (W x H x D)	345 x 85 x 303mm (excluding feet and extrusions when mirror is closed)
Weight	3.8Kg
Noise level	34dB (Normal Mode)/28dB (Eco Mode)
Ambient temperature	Operating 0°C-40°C, Storage -20°C-60°C
Air filter	Hybrid

MISCELLANEOUS

Lamp indicator light, power light, ceiling mount image, rear projection image, serial number label on side, Tabletop use (optional stand is required)

CERTIFICATION

UL60950-1/ cUL, FCC Part15 subpart B class B, CE Marking: EN61000-3-2, EN61000-3-3, EN55022(class B), EN55024(EMC directive), EN60950-1 (Low voltage directive), WEEE/RoHS/ErP(ot6) compliant, c-tick class B (Australia/New Zealand), GOST-R (Russia)

ACCESSORIES SUPPLIED

Remote control with batteries, RGB cable, power cord, cable cover, security label, user manual (detail & concise), Application CD, Wall mount (HAS-K250), Adapter cover

OPTIONAL ACCESSORIES

Replacement lamp	DT01381
Table top stand	TT-251
USB wireless adapter	USB-WL-11N

WARRANTY

Projector warranty	3 Years
Lamp warranty	6 months/5000 Hours**