

Wall Mount Installation TIPS



DIMENSIONS

Adhering to proper installation dimensions is always imperative, and is especially critical when dealing with an Ultra Short Throw Projector. Because the distance from the projector to the display surface is so short, even a **small** differential can cause a large error. In fact, the impact of not meeting dimensional requirements is roughly 5 times that of a normal throw distance projector. While you can manage an installation tolerance of one inch with a normal throw distance projector, you cannot manage this same tolerance with an Ultra Short Throw Projector.

Please pay attention and read the User Manual, Instruction Manual and Drawings that will be provided from manufacturer. If you have any questions or are unsure of any of the steps involved, please ask before proceeding.

SURFACE

Having a flat projection surface is very important. Since the throw distance is so short, waves or bends of the projection surface can produce wavy, un-even and out of focus images. For this reason – most pull up / down screens are not recommended. Hard board, flat wall or fixed frame screens are preferred for usage with an Ultra Short Throw Projector.



MARGIN

The very nature of an Ultra Short Throw Projector can produce some image distortion. The range of distortion is dependent upon the individual unit, operation temperature and various environmental factors. Look at the balance of whole image area, rather than focusing on a particular area or corner. When installing with an Interactive White Board (IWB), please allow for 1" margins on the (left, right, top, and bottom) edges, and then use the calibration function of the IWB. With a fixed frame installation, consider slightly over scanning for a video signal or allowing for the proper margin necessary for a computer signal.

STRATEGY

In an Ultra Short Throw installation, every adjustment is sensitive, with small changes having a large effect. Because many variables are involved, making adjustments can be confusing. But, in fact, this Ultra Short Throw Projector is a fixed projector, so the ideal location is always the same.



In order to get a square image without the use of electrical keystones, zoom and shift, please follow the steps describe on the next page.

Step 1 Preparation

Reset all Keystones (Keystone = 0), Electrical Zoom settings (Zoom = 100), etc... prior to starting adjustments.

Warm up the projector (30 minutes) in order to reduce image distortion.

Step 2 Horizontal Keystone

Adjust the Pitch (left-right angle) and Rotation to eliminate horizontal keystone effect. The left-right angle affects the top line of the image; the rotation affects the bottom line of image. Ignore vertical keystone during this process.

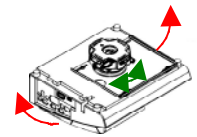
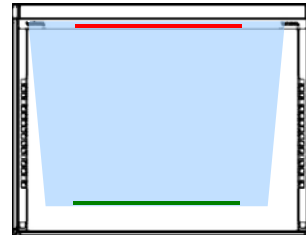
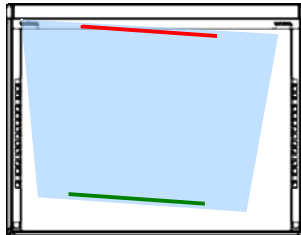

Step 3 Vertical Keystone

Optimize Focus and adjust Tilt Angle to eliminate horizontal keystone effect. The Focus adjustment will change the vertical keystone. If you cannot make both vertical edges parallel, you may need to go back Step2 and re-fine the Rotation.

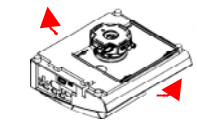
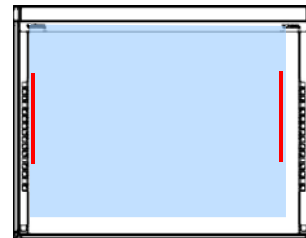
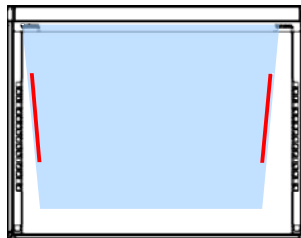

FOCUS + button

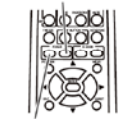

FOCUS - button

Step 3 Horizontal Position

Adjust horizontal position so it is centered on the display area.

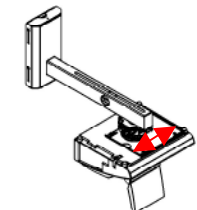
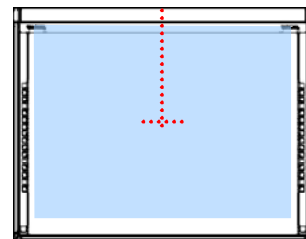
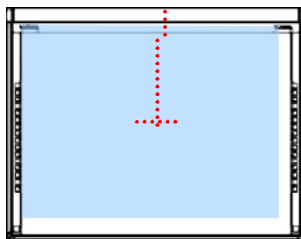

Step 4 Image Size

Adjust throw distance to match the length of top image with display area. You may see some geometrical distortions, so please do not try to fill entire area. You may need to do fine-tuning later (vertical and horizontal keystone or image positions). Leave a half inch margin.

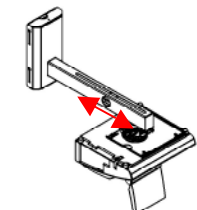
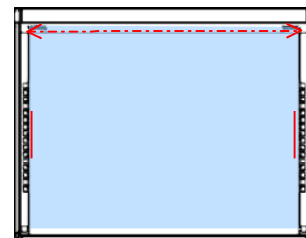
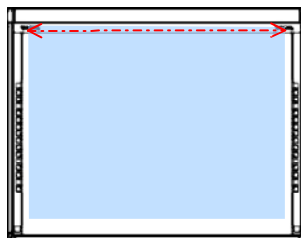

Step 4 Vertical Position

Adjust vertical position so it is centered in the display area.

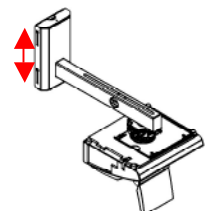
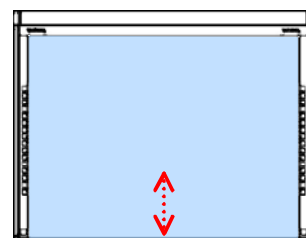
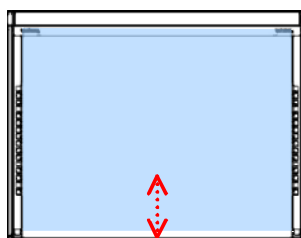

Hitachi CP-A100 Wall Mount Installation Guide

Option A

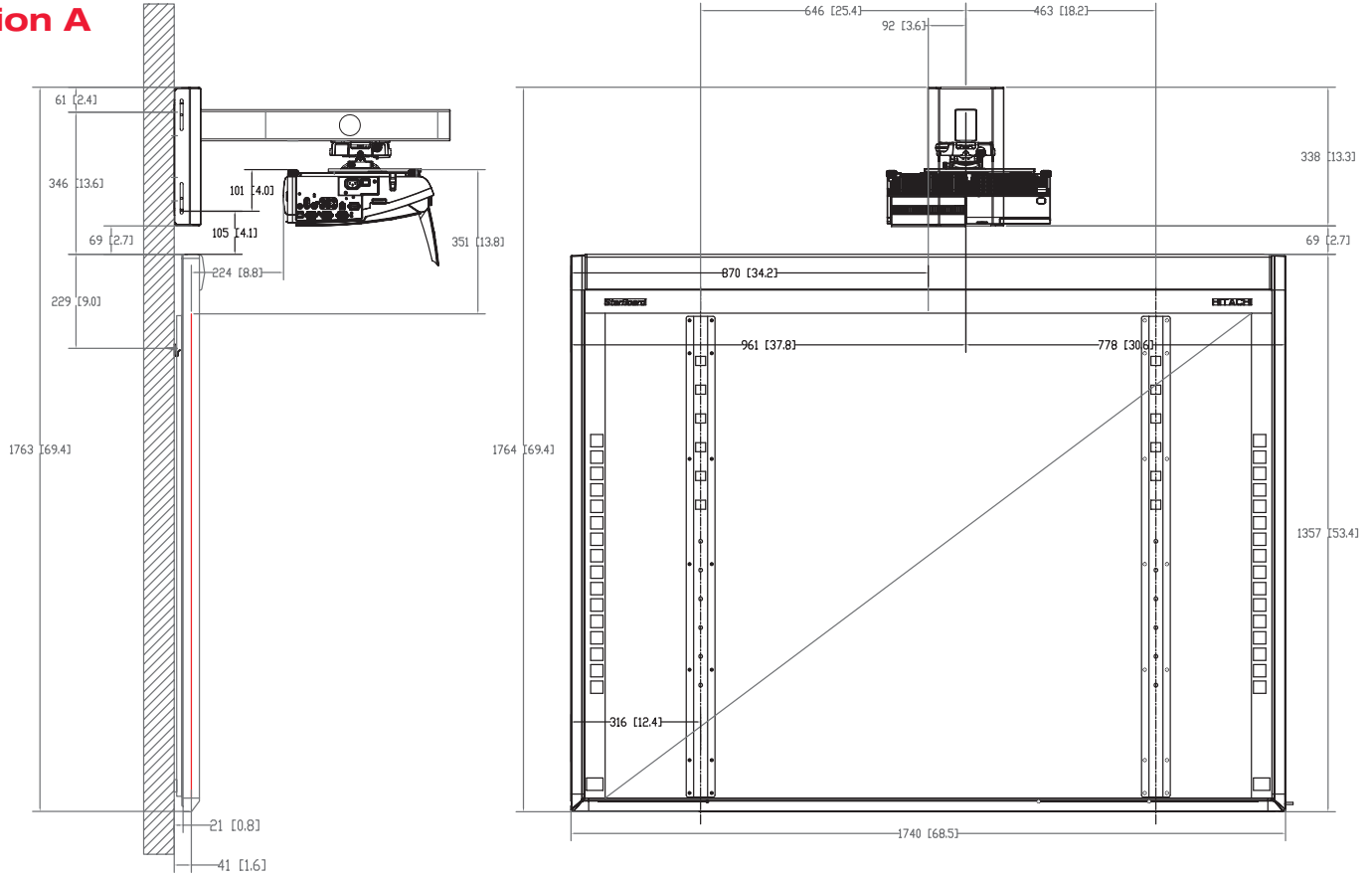

Option B

